

***Experimental Validation of
NDA for MSR Safeguards
FY20 Report***

***Prepared for
U.S. Department of Energy
Advanced Reactor Safeguards Program
September 30, 2020***

DISCLAIMER

This information was prepared as an account of work sponsored by an agency of the U.S. Government. Neither the U.S. Government nor any agency thereof, nor any of their employees, makes any warranty, expressed or implied, or assumes any legal liability or responsibility for the accuracy, completeness, or usefulness, of any information, apparatus, product, or process disclosed, or represents that its use would not infringe privately owned rights. References herein to any specific commercial product, process, or service by trade name, trade mark, manufacturer, or otherwise, does not necessarily constitute or imply its endorsement, recommendation, or favoring by the U.S. Government or any agency thereof. The views and opinions of authors expressed herein do not necessarily state or reflect those of the U.S. Government or any agency thereof.

Experimental Validation of Nondestructive Assay Capabilities for MSR Safeguards

Mark Croce, Katrina Koehler, Krystal De Castro, David Mercer, Sophie Weidenbenner, Matthew Carpenter, Duc Vo, Daniela Henzlova, Howard Menlove
Los Alamos National Laboratory

Michael Dion, Susan Smith, Louise Worrall
Oak Ridge National Laboratory

Jeffrey Sanders
Idaho National Laboratory

Daniel Becker, Joel Ullom
University of Colorado

1. Introduction

Current molten salt reactor (MSR) safeguards modeling efforts are limited by the lack of measurement data on realistic MSR materials as identified by advanced nuclear industry leaders and safeguards modeling experts. The challenging environment of an MSR where accessibility or direct sampling may be limited or impossible means that rapid, non-destructive characterization of fissile material and waste streams at MSRs is likely to be essential to meet regulatory requirements in a cost-effective way. An advanced systems approach is needed to meet safeguards requirements, and a main component of this approach is validated measurement performance capabilities. The goal of this project is to (1) measure gamma-ray and neutron signatures from nuclear material samples that have characteristics similar to material at an MSR facility, (2) assess limits of rapid anomaly detection and characterization of material compositions, and (3) evaluate nondestructive assay (NDA) concepts for harsh, high-radiation environments.

The experimental approach is based on a series of measurement campaigns using traditional and advanced NDA technologies to comprehensively evaluate performance with respect to material composition, spectral complexity, dose rate, cooling time, measurement environment, and other unique challenges of MSR facilities. Current MSR concepts include a wide range of possible designs including solid (salt-cooled designs) as well as liquid fuel (salt-fueled designs) with the nuclear material dissolved in molten salt for the latter [1]. Some designs may be considered a combination of the two, where certain fission products are allowed to enter the molten salt. Safeguards concepts for the salt-cooled designs will likely be more analogous to present-day reactor safeguards due to the use of fuel in solid form. The salt-fueled designs present a range of new safeguards challenges due to the liquid form of nuclear material and therefore the safeguards concepts are much less developed. As a result, salt-fueled designs are the primary focus of this NDA evaluation effort. An overview of the wide range of currently proposed MSR concepts is shown in Figure 1. It can be seen that the majority of the designs propose to use liquid fuel with several fuel variants including U and TRU fuel materials.

The NDA technologies employed in MSR safeguards will face a range of challenges in that the MSR present attributes of traditional bulk handling facilities (such as present-day reprocessing

facilities), however with much smaller amounts of material added and removed. Additionally many MSR concepts assume a closed reactor loop with the potential of on-line salt processing and refueling. From an operational standpoint, MSRs require high temperature (~700 °C) to keep the fuel salt in liquid phase. The fuel salts represent complex mixtures of actinides and fission products and exhibit a very high radiation background. This motivates evaluation with representative measurements of two scenarios: on-line NDA measurements of an operating MSR, and laboratory measurements of small samples taken from the process where a wider range of NDA technologies are applicable.

In FY20, a systematic approach was developed for the evaluation of NDA measurement capabilities and a measurement campaign at Los Alamos National Laboratory focused on gamma technology comparison was completed. Measured materials were chosen to evaluate limits of quantifying fissile material signatures in the presence of varying concentrations of fission products. Plans for neutron measurement campaigns at LANL and joint measurements to begin in FY21 at Oak Ridge National Laboratory and Idaho National Laboratory on increasingly representative materials have also been initiated.

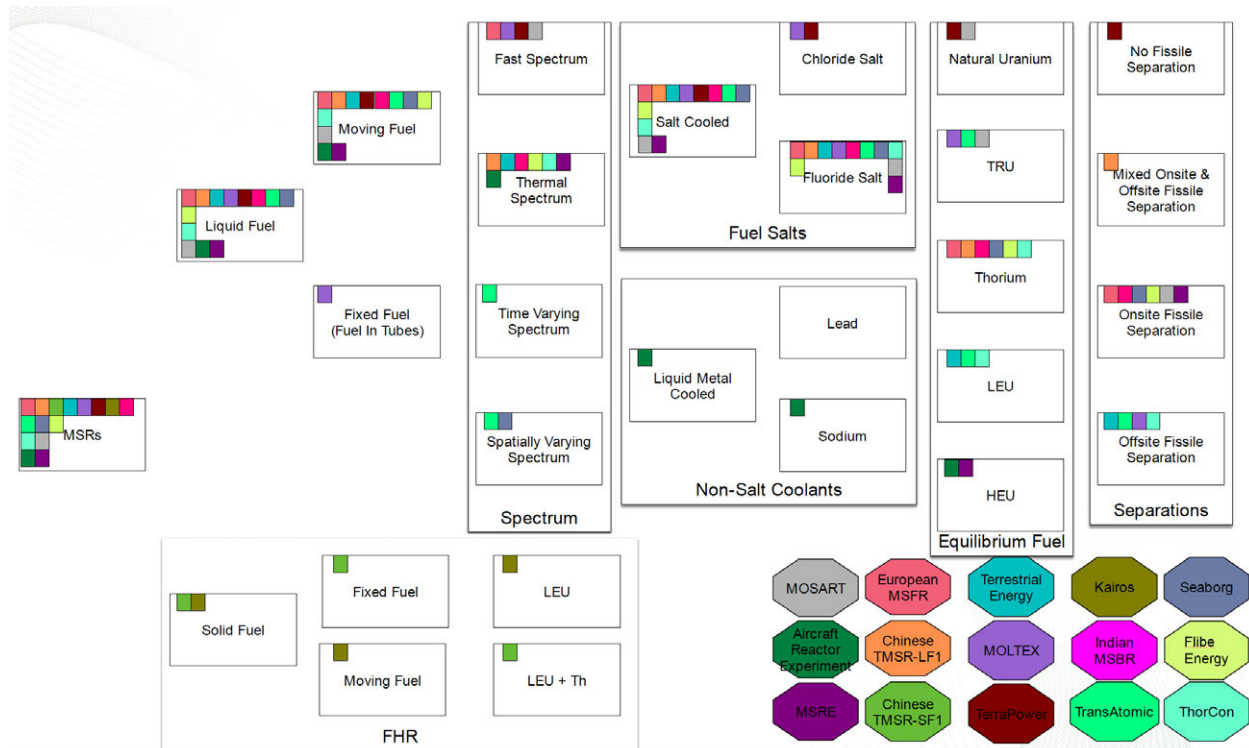

Figure 1: (From [1]) Overview of MSR technologies under development.

2. Analysis Approach

While MSR safeguards requirements are still being established, it is expected that timely detection of diversion of fissile material with high detection probabilities will depend on precision measurements of material composition throughout a facility. Verification of, or detection of changes in, fissile material content is the primary objective in the MSR safeguards approach. An

important goal of the project is to establish a common framework for evaluation of NDA measurement capabilities in order to facilitate comparisons between and selection of measurement technologies at key locations. Gamma-ray spectroscopy and correlated neutron counting are cornerstones of nuclear material accounting in safeguards of existing nuclear fuel cycle facilities. Experience and modeling results suggest that gamma-ray and neutron signatures will be similarly valuable for NDA of MSRs as the most direct methods of quantifying fissile material content throughout a facility.

In another Advanced Reactor Safeguards project, the Transient Simulation Framework of Reconfigurable Models (TRANSFORM) has been developed at ORNL to study the system-level dynamics of MSRs. Experimental design in this project is informed by the modeling work, and experimental results will be used to inform safeguards models. TRANSFORM provides a way to implement system-level specifications including pipe dimensions, pump characteristics and other details that are extremely useful to evaluate various operating conditions [2]. It is based on the object oriented, open-source Dymola Modelica modeling language. Currently, a variation on the Molten Salt Demonstration Reactor (MSDR) has been modeled in TRANSFORM and is being used to predict fission product movement and core reactivity. The model layout as displayed in the software is shown in Figure 2.

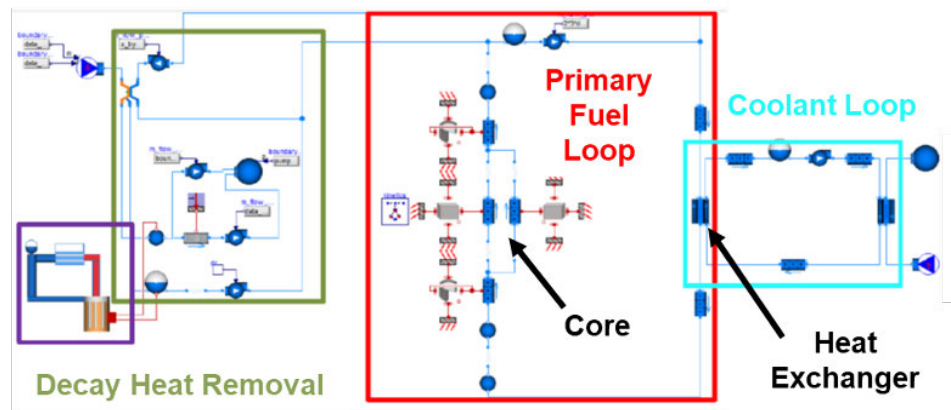

Figure 2: Layout of the MSDR in TRANSFORM being used for simulations of dynamic fission product concentrations.

Currently, an abbreviated population of fission products are handled as trace materials in the TRANSFORM model. These trace substances are carried in the bulk molten fuel-salt mixture; here it is a FLiBe salt matrix. It is possible to obtain concentrations of any fission product at any location in the model. Therefore, this is being utilized to develop an understanding of the dynamic behavior of fission product signatures. This data can be used to determine how fission product signatures vary with time and fissile content burnup. These results are used to inform experimental validation work about key measurement locations, and detector requirements.

The analysis approach begins with identifying relevant signatures. For gamma spectroscopy methods, energy peaks associated with fissile nuclides are identified and uncertainty is quantified for a given measurement time. With additional information about the process, these peaks could be compared with fission product peaks as an indicator of normal or off-normal conditions. For neutron counting methods, time-correlated signatures resulting from fission rather than (alpha, n)

reactions can be used. Additionally, total neutron counting can be used in process monitoring applications to confirm presence or absence of nuclear material. The main performance metric for each measurement is the sensitivity with which it can detect changes in fissile material concentration in a given measurement time. A staged approach to measurements begins with immediately available fuel cycle materials in order to answer fundamental questions about observable signatures and progresses towards increasingly realistic MSR materials. The results are expressed in terms of the statistical uncertainty achievable for relevant signatures and intended as input values for MSR safeguards system modeling efforts.

Gamma NDA measurements include spectroscopic and non-spectroscopic technologies. Non-spectroscopic gamma detectors such as ion chambers are useful for high-dose environments but only provide a measure of total gamma-ray flux. For the complex mixtures of actinides, fission, and activation products encountered in an MSR, a non-spectroscopic gamma measurement therefore provides very limited information that generally cannot be used in quantification of specific nuclides. As a result, this evaluation of gamma NDA capabilities is focused on spectroscopic technologies. Primary metrics in gamma spectroscopy include detection efficiency, count rate capability, dynamic range, and energy resolution. Specific detector types were chosen to cover this parameter space. Sodium iodide scintillation detectors are a well-established low-resolution detector type (approximately 8% FWHM resolution at 662 keV). They have been evaluated for process monitoring using a principal component analysis approach [3]. However, their resolution is insufficient to distinguish nuclides in complex MSR-relevant materials. High-purity germanium (HPGe) detectors are the commercially available standard for high-resolution gamma spectroscopy, with low-energy planar detectors yielding energy resolution of approximately 550 eV FWHM at 122 keV. Microcalorimeter spectrometers are an emerging ultra-high energy resolution gamma spectroscopy technology with the first instruments now being built for use in nuclear facilities and analytical laboratories [4-5]. Energy resolution of microcalorimeter gamma spectroscopy is typically 60-100 eV FWHM at 129 keV. This work considers sodium iodide, high-purity germanium, and microcalorimeter detectors (Figure 3). Based on FY20 results, intermediate-resolution detectors including CdZnTe will be considered in the next measurement campaigns.

To determine the sensitivity of a particular measurement method, regions with the best signatures of the various isotopes are chosen. These regions are fit with a sum of peak shapes, and the peak areas with their associated statistical uncertainty are saved. These areas and uncertainties are then scaled to correspond to a 24-hour measurement for each data type (i.e. HPGe and microcalorimeter data). Since the process is a chemical process, particular isotopes do not need to be tracked as much as elements. As a result, a strong ^{241}Am peak is all that is needed to quantify the Am content, so further quantification of the lesser constituent ^{243}Am need not be considered. For each element, the peak that provides the lowest uncertainty is used.

Neutron NDA technologies for safeguards applications focus on detection of individual and/or correlated neutron signatures from spontaneous and induced fissions within the nuclear materials. Passive neutron NDA technologies require sufficient neutron emission rate (i.e. spontaneous fission and (α, n) neutrons) and are typically used for assay of Pu-bearing materials [6]. Due to the low spontaneous fission yield of U-isotopes (^{233}U , ^{235}U , ^{238}U), U-bearing materials require

active NDA and are typically assayed using active interrogation with an external neutron source [6].

The neutron detection technologies traditionally used in safeguards applications include primarily ^3He -based proportional counters and fission chambers. ^3He -based instruments have been a gold standard of nuclear safeguards for the past decades and provide high neutron detection efficiency to support quantitative nuclear material assay. Fission chambers are typically used in applications with high gamma dose rates, such as spent fuel measurements and are capable of operating at dose rates of up to 10,000 R/hr, however they provide very low detection efficiency on the order of 0.01%. Also, the fission chambers present shipping and regulatory control issues because of the fissile material content. A new technology developed for high gamma background applications, such as MSRs, is the High Dose Neutron Detector (HDND). The HDND technology is based on boron-lined proportional counters, which provide inherent fast signal characteristics and high gamma dose tolerance [7]. In addition, the HDND provides simultaneous monitoring of the gamma-ray emission rate. This work considers ^3He detectors, fission chambers, and the HDND (Figure 3).

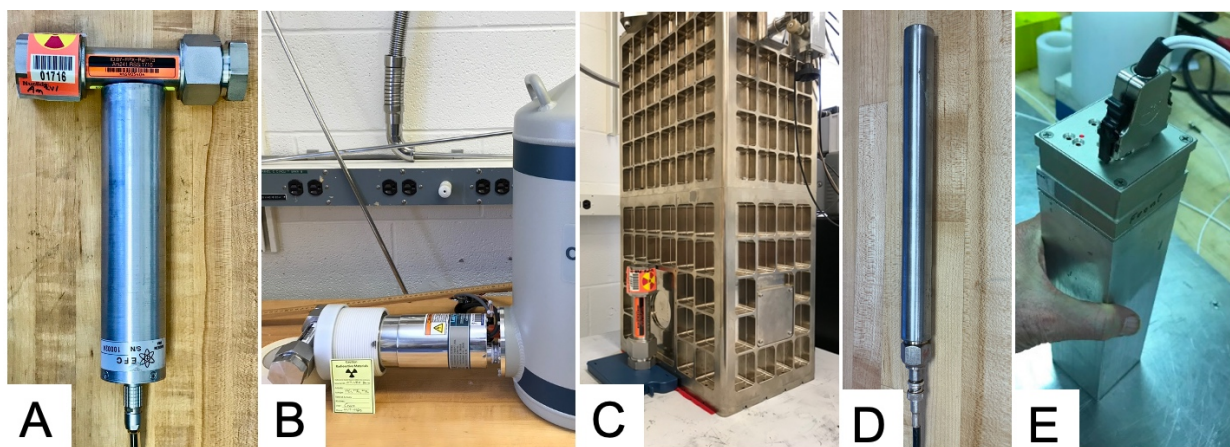

Figure 3: Primary detector types considered in this work: A) sodium iodide scintillation detector (NaI), B) planar high-purity germanium detector (HPGe), C) SOFIA microcalorimeter gamma spectrometer, D) ^3He neutron detector, E) mini High Dose Neutron Detector (miniHDND)

3. LANL Measurement Campaign

A series of samples from an aqueous separation process of spent nuclear fuel at Argonne National Laboratory was available at Los Alamos National Laboratory. These well-characterized samples are ideal for an initial evaluation of the ability of gamma spectroscopy methods to quantify fissile material signatures in the presence of varying concentrations of fission products and as actinide components are removed from the material. Figure 4 and Table 1 summarize the measured samples and observable nuclides by gamma spectroscopy. Measurements of each sample were completed with a NaI(Tl) detector from EFC Company (Figure 3A, [8]), a Canberra GL1015 low-energy HPGe detector (Figure 3B, [9]), and the SOFIA microcalorimeter spectrometer (Figure 3C, [4-5]).

Example spectra from each detector are shown in Figure 5. Many of the best spectral signatures are observed in the 55-125 keV region. The NaI detector has insufficient resolution to make use of this complex spectral region for quantitative analysis, while the HPGe and microcalorimeter detectors resolve a number of important peaks. Therefore, quantitative analysis efforts focused on the two high-resolution gamma spectroscopy technologies. As components are removed from the spent fuel, especially fission products, actinide signatures become more clear. Although the age of the spent fuel used in this work leads to a moderate level of fission product activity compared with intact freshly-discharged fuel elements, in many liquid-fueled MSR designs an offgas system is designed to remove gaseous fission products. Since many fission products have Xe or Kr precursors, over 40% of fission products are expected to leave the core including a large fraction of Cs, Sr, and I which are collected in the offgas system [1]. Therefore, direct quantification of important actinides in fuel salt may be possible by NDA for a sampling loop in an operating MSR or for salt samples with a short cooling time. Further work including comparison with TRANSFORM model results is required to test this hypothesis.

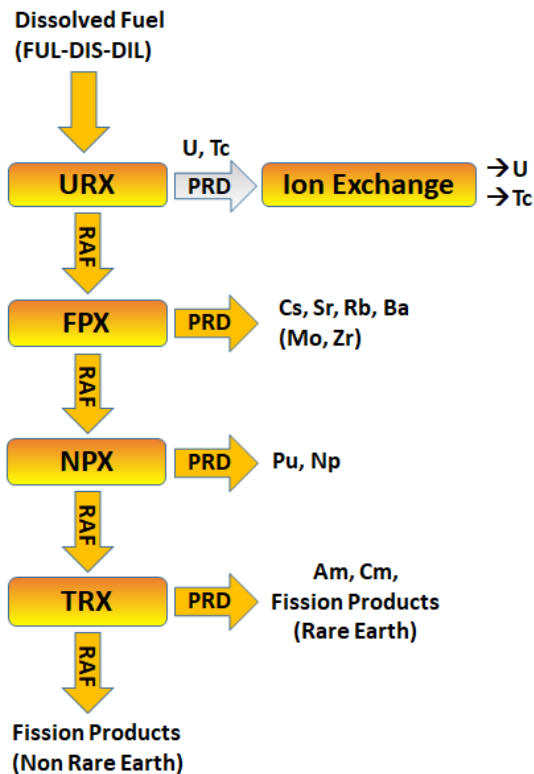

Figure 4: Flowchart of the spent fuel separation process as communicated by Argonne National Laboratory. The eight samples indicated by orange arrows were sent to Los Alamos for measurements.

Sample	Description	Observable Nuclides	Pu	Np	Am	Eu	Cm
07-FUL-DIS-DIL2	Input Fuel	^{134}Cs , ^{137}Cs , ^{154}Eu , ^{155}Eu , $^{241}\text{Am}/^{241}\text{Pu} \rightarrow ^{237}\text{U}$, $^{243}\text{Cm}/^{243}\text{Am} \rightarrow ^{239}\text{Np}$, Pu X-rays	--	--	^{241}Am 59.5 keV	^{154}Eu 123 keV	Pu X-ray 103.7 keV
07-URX-RAF-T2	U/Tc removed	^{134}Cs , ^{137}Cs , ^{154}Eu , ^{155}Eu , $^{241}\text{Am}/^{241}\text{Pu} \rightarrow ^{237}\text{U}$, $^{243}\text{Cm}/^{243}\text{Am} \rightarrow ^{239}\text{Np}$, Pu X-rays	--	--	^{241}Am 59.5 keV	^{154}Eu 123 keV	Pu X-ray 103.7 keV
07-FPX-RAF-T2	U/Tc/Cs/Sr removed	$^{60}\text{Co}^*$, ^{137}Cs , ^{154}Eu , ^{155}Eu , $^{237}\text{Np}^*$, $^{238}\text{Pu}^\dagger$, $^{239}\text{Pu}^*$, $^{241}\text{Am}/^{241}\text{Pu} \rightarrow ^{237}\text{U}$, $^{243}\text{Cm}/^{243}\text{Am} \rightarrow ^{239}\text{Np}$, U X-rays, Np X-rays, Pu X-rays	^{239}Pu 129 keV* ^{238}Pu 99.9 keV †	^{237}Np 312 keV*	^{241}Am 59.5 keV	^{154}Eu 123 keV	Pu X-ray 103.7 keV
07-FPX-PRD-T2	Cs/Sr fraction	^{137}Cs , $^{241}\text{Am}/^{241}\text{Pu} \rightarrow ^{237}\text{U}^\dagger$	--	--	^{241}Am 59.5 keV †	--	--
07-NPX-RAF-T3	U/Tc/Cs/Sr/Np/Pu removed	$^{60}\text{Co}^*$, $^{126}\text{Sb}^*$, $^{137}\text{Cs}^*$, ^{154}Eu , ^{155}Eu , $^{241}\text{Am}/^{241}\text{Pu} \rightarrow ^{237}\text{U}$, $^{243}\text{Cm}/^{243}\text{Am} \rightarrow ^{239}\text{Np}$, $^{244}\text{Cm}^*$, $^{245}\text{Cm}^*$, Np X-rays, Pu X-rays	--	--	^{241}Am 59.5 keV	^{154}Eu 123 keV	Pu X-ray 103.7 keV
07-NPX-PRD-T3	Np/Pu fraction	$^{137}\text{Cs}^*$, ^{237}Np , ^{238}Pu , ^{239}Pu , ^{240}Pu , $^{241}\text{Am}/^{241}\text{Pu} \rightarrow ^{237}\text{U}$, Pa X-rays, Np X-rays, U X-rays	^{238}Pu 99.9 keV	^{237}Np 312 keV* ^{237}Np 86.5 keV †	^{241}Am 59.5 keV	--	--
07-TRX-RAF-T3	U/Tc/Cs/Sr/Np/Pu/Am/Cm/RE removed	$^{60}\text{Co}^*$, $^{125}\text{Sb}^*$, $^{126}\text{Sb}^*$, ^{126}Sn , $^{137}\text{Cs}^*$, $^{154}\text{Eu}^*$, $^{241}\text{Am}/^{241}\text{Pu} \rightarrow ^{237}\text{U}$, Np X-rays*, Pu X-rays* [$^{243}\text{Cm}/^{243}\text{Am} \rightarrow ^{239}\text{Np}$ visible in other fractions, but not T3]	--	--	^{241}Am 59.5 keV	^{154}Eu 123 keV*	--
07-TRX-PRD-T3	Am/Cm/RE fraction	$^{137}\text{Cs}^*$, ^{154}Eu , ^{155}Eu , $^{241}\text{Am}/^{241}\text{Pu} \rightarrow ^{237}\text{U}$, $^{243}\text{Cm}/^{243}\text{Am} \rightarrow ^{239}\text{Np}$, $^{244}\text{Cm}^*$, $^{245}\text{Cm}^*$, Pu X-rays	--	--	^{241}Am 59.5 keV	^{154}Eu 123 keV	Pu X-ray 103.7 keV

Table 1: Summary of samples from Argonne spent fuel separation process used for the measurement campaign at Los Alamos. Spent nuclear fuel was separated in stages. RE refers to Rare Earth fission products such as Eu. Gamma measurements were completed using NaI, HPGe, and microcalorimeter detectors. Within the Observable Nuclides column, an asterisk (*) denotes signatures visible in only HPGe data and a dagger (†) denotes signatures visible in only microcalorimetry data. Other signatures are common between measurement types.

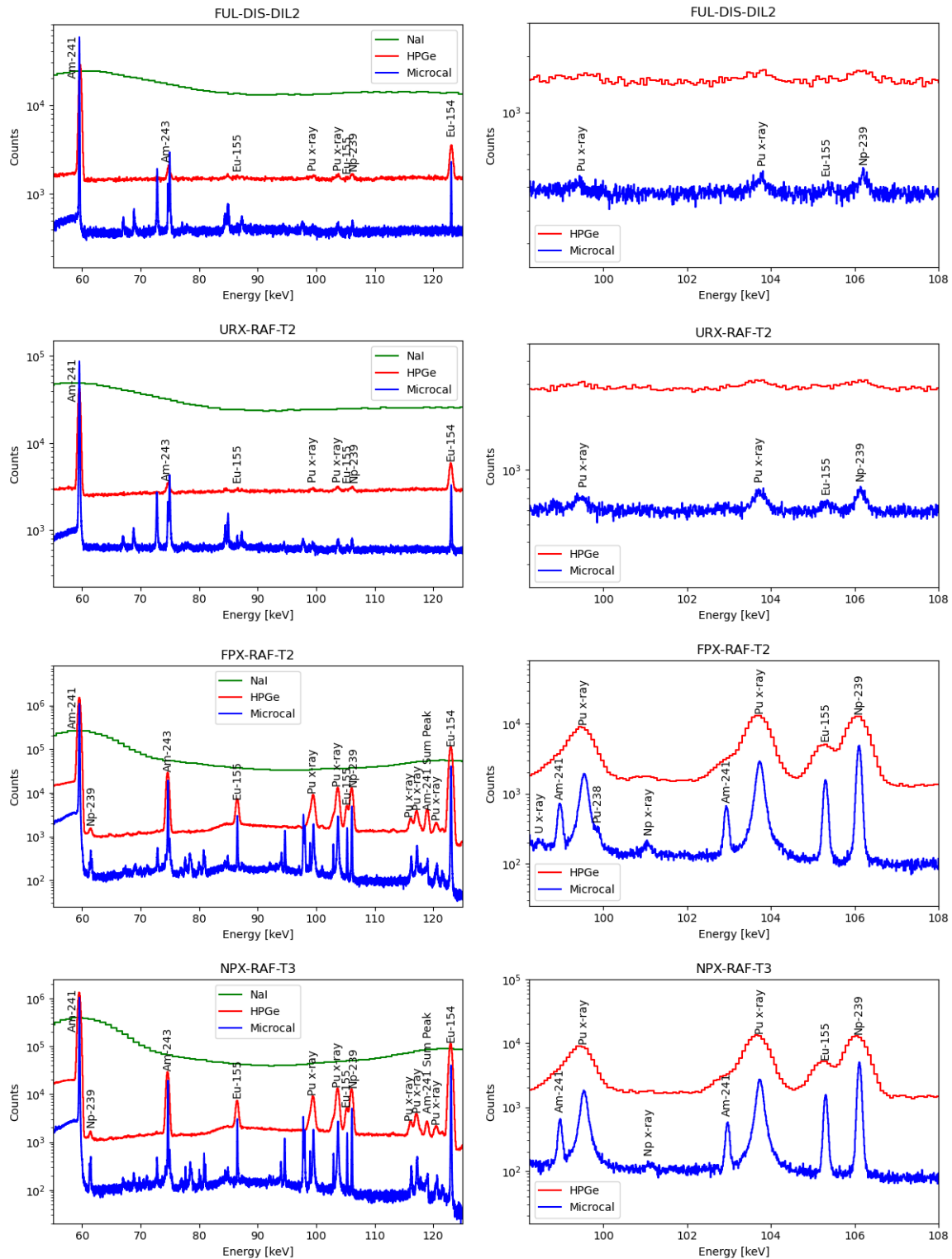

Figure 5: Measured spectra for 07-FUL-DIS-DIL2, 07-URX-RAF-T2, 07-FPX-RAF-T2, and 07-NPX-RAF-T3 illustrate effects of removing components from irradiated fuel. The 55-125 keV region is shown on the left, and the 98-108 keV region is shown on the right.

Quantitative analysis of the constituents within the samples was performed on both the microcalorimeter and HPGe measurements. For each sample, key regions were fit to determine the peak areas and uncertainties, with uncertainties coming from the minimization covariance matrix. The peak areas and uncertainties were scaled to match those of a 24-hour microcalorimeter measurement with a count rate of 5,000 cps for microcalorimetry data and 10,000 cps for HPGe data. These count rates are typical for the current SOFIA microcalorimeter spectrometer and the low-energy planar HPGe detector used in this work. The microcalorimeter instrument being built for deployment to Idaho National Laboratory in FY21 is expected to be capable of 10,000 cps.

Because chemical processing in an MSR does not discriminate between the isotopes of a particular element, the area of a peak of any isotope of a particular element with the lowest uncertainty is most sensitive to possible elemental diversion (see Table 1 for peaks used). The percent uncertainties in Tables 2-3 show the lowest uncertainty for a peak coming from an isotope (or X-ray) corresponding to a particular element. The lower these uncertainties, the easier it is to detect diversion of the fissile material. It is important to note that this analysis considers only statistical uncertainties. Green shading indicates a significant advantage of a particular measurement technology. For example, uncertainty of Pu quantification in the material just before Pu/Np removal is 2.3% for microcalorimetry and 8.5% for HPGe due to having to fit the ^{239}Pu peak at 129 keV in the HPGe rather than the ^{238}Pu peak at 99.9 keV, which is accessible in the 100 keV spectral region with a microcalorimeter measurement (see Figure 5 and Table 1). Only microcalorimetry is able to resolve Am, interpreted to be an impurity, in the Cs/Sr fraction. Conversely, HPGe measurements of the raffinate during a Cs removal shows a ^{237}Np signature at 312 keV, which is inaccessible for a microcalorimeter detector designed for efficiency in the 100 keV region. The ^{237}Np signature that is accessible in a microcalorimeter spectrum has interference with a ^{155}Eu at nearly the same energy (86.5 keV). These peaks may be resolvable by microcalorimetry, but this could not be confirmed in existing measurement data. Systematic uncertainty has the potential to be significant due to peak overlaps and complex background shapes particularly in the 100 keV region, and merits further study. The improved resolution of the microcalorimeter data, where peaks are better resolved from each other and a narrower background region is relevant, may substantially reduce this type of uncertainty contribution and therefore allow peaks in this region to be more confidently used for quantitative analysis.

Sample	Description	Pu	Np	Am	Eu	Cm
07-FUL-DIS-DIL2	Input Fuel	--	a	0.029	0.12	1.2*
07-URX-RAF-T2	U/Tc removed	--	a	0.047	0.55	0.96*
07-FPX-RAF-T2	U/Tc/Cs/Sr removed	2.3	a	0.0098	0.067	0.1*
07-FPX-PRD-T2	Cs/Sr fraction	--	--	11.5	--	--
07-NPX-RAF-T3	U/Tc/Cs/Sr/Np/Pu removed	--	--	0.0094	0.072	0.22*
07-NPX-PRD-T3	Np/Pu fraction	0.38	0.38	0.0098	--	--
07-TRX-RAF-T3	U/Tc/Cs/Sr/Np/Pu/ Am/Cm/RE removed	--	--	0.20	--	--
07-TRX-PRD-T3	Am/Cm/RE fraction	--	--	0.011	0.062	0.059*

Table 2: Summary of best results for each element within each sample using microcalorimeter measurements. The values in the table correspond to the 1-sigma percent uncertainty of the highest statistics peak of an isotope (or X-ray denoted by an asterisk (*)) corresponding to the presence of the element listed. The uncertainties assume a 24-hour microcalorimeter measurement with a count rate of 5,000 cps. Dashes indicate that the element could not be quantified with available data. Green shading indicates a significant advantage of microcalorimeter measurements compared with HPGe. ^aThere may be a signature of ²³⁷Np at 86.5 keV near the ¹⁵⁵Eu peak at 86.55, but this is not clearly resolvable in existing data.

Sample	Description	Pu	Np	Am	Eu	Cm
07-FUL-DIS-DIL2	Input Fuel	--	--	0.024	0.13	1.0*
07-URX-RAF-T2	U/Tc removed	--	--	0.027	0.15	1.4*
07-FPX-RAF-T2	U/Tc/Cs/Sr removed	8.5	2.9	0.0047	0.015	0.054*
07-FPX-PRD-T2	Cs/Sr fraction	--	--	--	--	--
07-NPX-RAF-T3	U/Tc/Cs/Sr/Np/Pu removed	--	--	0.0049	0.015	0.058*
07-NPX-PRD-T3	Np/Pu fraction	0.034	0.044	0.0050	--	--
07-TRX-RAF-T3	U/Tc/Cs/Sr/Np/Pu/Am/Cm/RE removed	--	--	0.036	1.0	--
07-TRX-PRD-T3	Am/Cm/RE fraction	--	--	0.011	0.01	0.04*

Table 3: Summary of best results for each element within each sample using HPGe measurements. The values in the table correspond to the 1-sigma percent uncertainty of the highest statistics peak of an isotope (or X-ray denoted by an asterisk ()) corresponding to the presence of the element listed. The uncertainties assume a 24-hour HPGe measurement with a count rate of 10,000 cps. Dashes indicate that the element could not be quantified with available data. Green shading indicates a significant advantage of HPGe compared with microcalorimeter measurements.*

An initial evaluation of miniHDND [10] was performed during FY20 in preparation for the measurement activities outlined in the following section. Basic neutron and gamma counting capability was evaluated using ^{252}Cf neutron and ^{137}Cs gamma sources in the form of high voltage plateaus. It should be emphasized that gamma sensitivity of miniHDND is tunable via gain of each signal processing amplifier. In this initial evaluation all three amplifiers were matched to provide the same gamma response. For practical applications, the gain on the gamma cell can be increased to improve gamma sensitivity, while maintaining the lower gamma sensitivity of the neutron cells and thus not affecting their performance. The ^{137}Cs high voltage plateaus are shown in Figure 6 and indicate good gain matching of the three detector amplifiers. Note that the dose rate from these sources is very low (~60 mR/hr on contact) as this measurement was a part of an initial characterization. Further evaluation will be performed with high gamma dose rates in FY21.

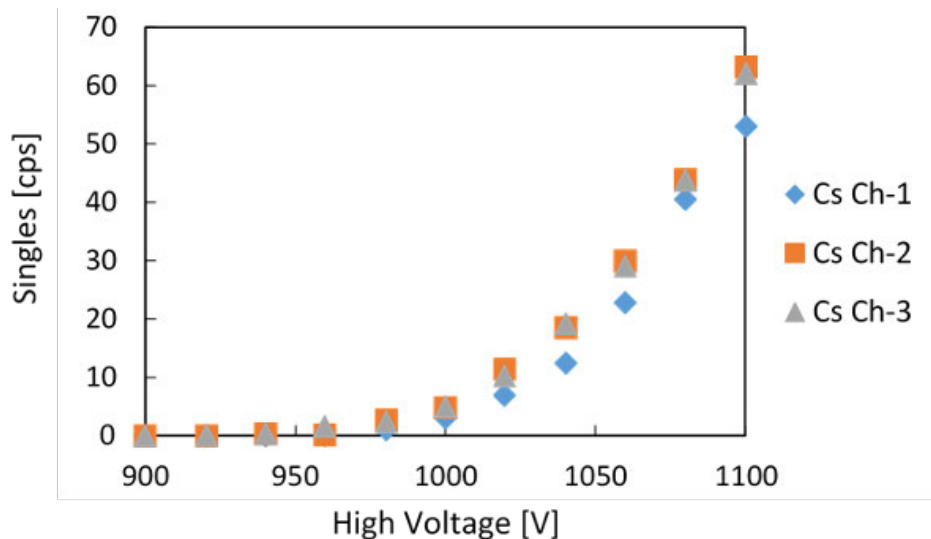

Figure 6: High voltage plateaus for all three miniHDND detection cells in response to ^{137}Cs gamma rays.

Similarly, the neutron performance was evaluated using a ^{252}Cf neutron source and is summarized in Figure 7. Combining the gamma and neutron results, the suggested operating voltage for the instrument is ~ 900 V. The neutron detection efficiency for the current miniHDND configuration therefore corresponds to 0.12% for a ^{252}Cf source at the detector face.

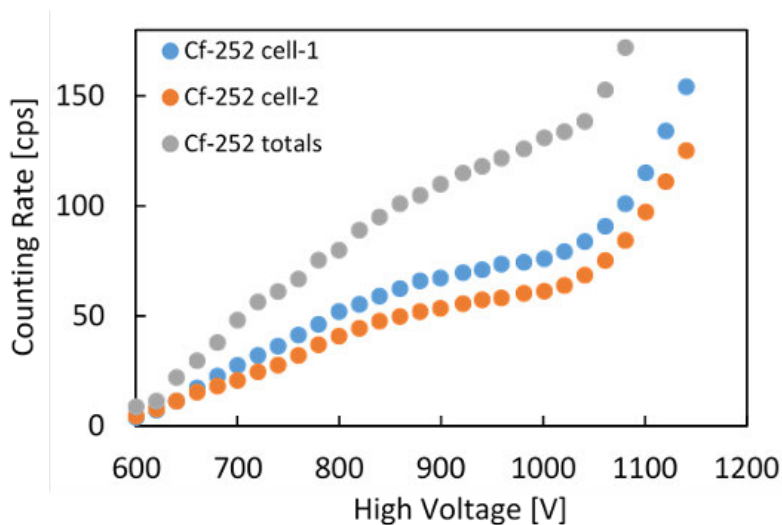

Figure 7: High voltage plateaus for the two miniHDND neutron detection cells and their summed response (totals) in response to ^{252}Cf neutrons.

Due to the MSR facility configuration (a closed loop with potential for on-site salt processing and refueling), it can be anticipated that NDA measurements would be performed on flowing fuel salt in MSR piping, on salt samples extracted from the process or on material for refuel. The

measurements of flowing fuel salt could use total neutron counting as well as total gamma counting in order to establish process monitoring capability and provide information on presence or absence of nuclear material in various streams. Higher efficiency neutron detectors could also surround a pipe to enable correlated neutron measurements for assay of flowing nuclear material. Figure 8 illustrates the concept of measuring a side stream of the reprocessing liquid that was considered in the past. Because the MSR fuel cycle materials do not typically contain significant spontaneous fission signatures, use of ^{252}Cf source neutrons or neutron generator would have to be considered to induce fission reactions in the fuel combined with the time-correlated counting of the measuring the induced fission reactions in the uranium fissile material.

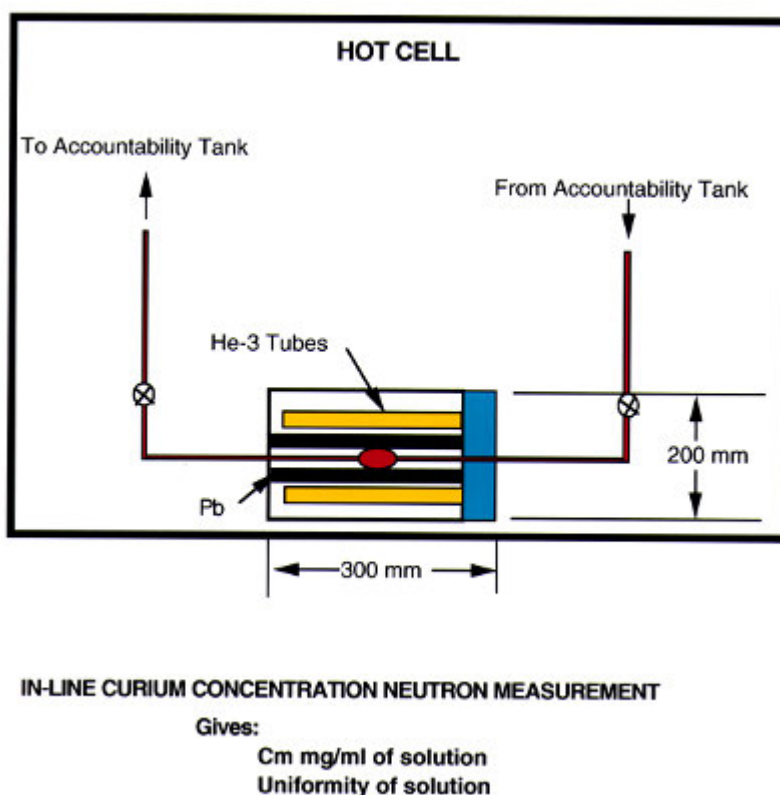

Figure 8: Illustration of on-line coincidence counting concept originally considered for reprocessing applications.

Neutron assay of samples from the process could also be used for quantitative assay, similarly to instruments used in current reprocessing and fuel fabrication facilities (AVIS [11], INVS [12]). In all such measurement scenarios, the deployed technology will have to satisfy unique MSR challenges of high radiation backgrounds, high temperatures and remote operations. The key focus of this neutron detection technology intercomparison will therefore be on a set of criteria including capability to provide reliable neutron detection in competing high gamma backgrounds, advanced process monitoring capabilities, and ability to operate in high temperature environments. Practical

considerations such as robustness, maintenance requirements and compatibility with remote-handling environments will also be assessed.

The technologies to be compared will include current safeguards standard detectors (fission chambers and ^3He tubes), which will be compared with the miniHDND prototype. For the tests each of the traditional detectors (^3He , fission chambers) will be enclosed in a comparable moderating enclosure of similar footprint to the miniHDND. The following series of measurements will be performed to assess MSR-relevant performance capabilities:

- To establish neutron counting capability of each instrument in competing high gamma radiation fields, dedicated measurements will be performed to:
 - Calibrate the neutron and gamma response as a function of high voltage and gamma dose using known gamma sources.
 - Evaluate high voltage response at LANL Radiation Instrumentation Calibration Facility. The facility offers a 1000 Ci ^{137}Cs source and provides access to gamma dose rates of hundreds of R/hr.
 - Compare the technologies in a high gamma dose environment with a range of neutron sources of MSR relevance.
- Process monitoring capability will be assessed to evaluate each system performance for moving or changing nuclear material.
- Moderator materials for high temperature performance
 - This is an important aspect, and will be largely evaluated in MCNP, where various alternative moderating materials with higher melting points than HDPE will be explored.

4. ORNL Measurement Campaign

Spent nuclear fuel rods available at Oak Ridge National Laboratory, summarized in Table 4, offer an opportunity to evaluate NDA measurement performance with extremely high activity materials [13]. The rods came from fuel assemblies irradiated at the North Anna Power Station and were shipped to ORNL in 2016. Rod average burnup is greater than 45 GWd/MTU and documented discharge dates range from 1994-2010. Some of the fuel rods are undergoing processing, which would allow comparison of measurement performance for both intact fuel rods and cut fuel elements where gaseous fission products have been released. In FY21, we will conduct a measurement campaign at the ORNL Irradiated Fuels Examination Laboratory (Figures 9-10) using the same kinds of detectors and analysis approach as for the LANL measurement campaign. The questions that will be considered by this measurement campaign include:

1. What are the observable signatures of fissile material content available with each measurement technology?
2. How precisely can these signatures be quantified?
3. What are the operational limitations of each measurement technology in a high-background, high-count rate facility environment?

Contingent on approvals, the SOFIA microcalorimeter gamma spectrometer will be transported to ORNL and used for measurements along with high-purity germanium and sodium iodide. High-Dose Neutron Detector (HDND) and ^3He -based detectors will follow pending finalization of measurement location discussions. In 2017, ORNL completed HPGe and NaI measurements of the intact fuel rods which will be used for initial evaluation of the analysis framework and prioritization of new measurements. New HPGe and NaI measurements will be completed along with microcalorimeter measurements to allow direct comparison of results for the same cooling time and processing.

Additional materials are expected to be available at ORNL in FY22, contingent on other project schedules. These materials may include irradiated MSR salts with or without fissile material, or irradiated fissile material in order to evaluate signatures in the presence of short-lived fission products. It may be possible to perform dedicated irradiations of fissile targets to access very short-lived nuclides.

ID	Assembly	Initial Enrichment	Approximate Burnup	Discharge Date
30AD05	30A	4.55 wt%	52.0 GWd/MTU	2010
30AE14	30A	4.55 wt%	52.0 GWd/MTU	2010
30AG09	30A	4.55 wt%	52.0 GWd/MTU	2010
30AK09	30A	4.55 wt%	52.0 GWd/MTU	2010
30AP02	30A	4.55 wt%	52.0 GWd/MTU	2010
5K7C05	5K7	4.55 wt%	53.3 GWd/MTU	2008
5K7K09	5K7	4.55 wt%	53.3 GWd/MTU	2008
5K7O14	5K7	4.55 wt%	53.3 GWd/MTU	2008
5K7P02	5K7	4.55 wt%	53.3 GWd/MTU	2008
6U3I07	6U3	4.45 wt%	52.7 GWd/MTU	2006
6U3K09	6U3	4.45 wt%	52.7 GWd/MTU	2006
6U3L08	6U3	4.45 wt%	52.7 GWd/MTU	2006
6U3M03	6U3	4.45 wt%	52.7 GWd/MTU	2006
6U3M09	6U3	4.45 wt%	52.7 GWd/MTU	2006
6U3O05	6U3	4.45 wt%	52.7 GWd/MTU	2006
6U3P16	6U3	4.45 wt%	52.7 GWd/MTU	2006
3F9D07	3F9	4.25 wt%	52.3 GWd/MTU	2003
3F9N05	3F9	4.25 wt%	52.3 GWd/MTU	2003
3F9P02	3F9	4.25 wt%	52.3 GWd/MTU	2003
3D8B02	3D8	4.2 wt%	55.0 GWd/MTU	1999
3D8E14	3D8	4.2 wt%	55.0 GWd/MTU	1999
3A1B16	3A1	4.0 wt%	50 GWd/MTU	1994
3A1F05	3A1	4.0 wt%	50 GWd/MTU	1994
F35K13	F35	3.59 wt%	58 GWd/MTU	unknown
F35P17	F35	3.59 wt%	58 GWd/MTU	unknown

Table 4: Summary of spent fuel rods available at the ORNL Irradiated Fuels Examination Laboratory. Some of the fuel rods are undergoing processing.

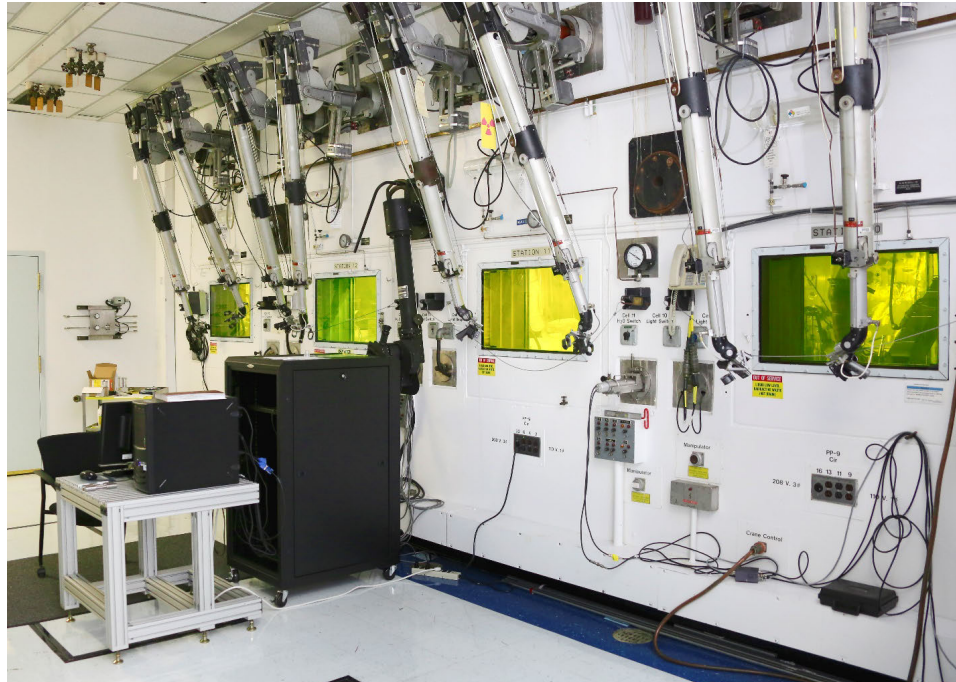

Figure 9: (From ORNL/SPR-2017/535) Photograph of the wall of the east cell bank. The two windows on the right-hand side of the photograph surround the port where the measurements can be performed. A small NaI(Tl) detector can be seen mounted at the exit of the collimator.

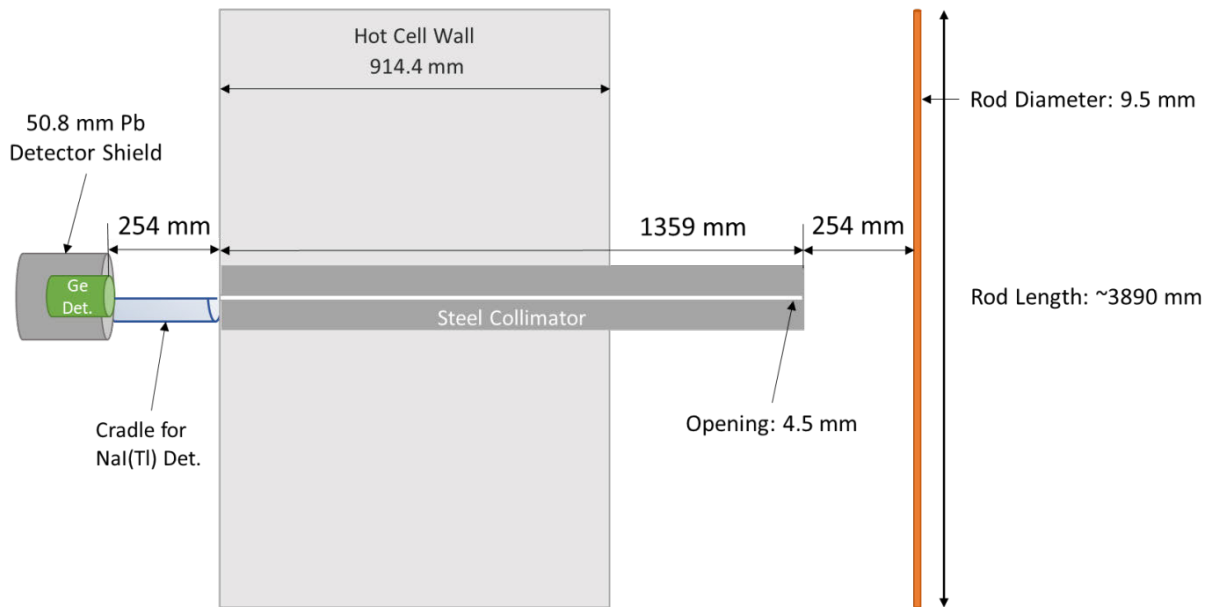

Figure 10: (From ORNL/SPR-2017/535) Diagram of the measurement geometry successfully used for previous gamma spectroscopy measurements of spent fuel rods. The steel collimator extends through and beyond the hot cell concrete wall to within 254 mm of the fuel rod.

5. INL Measurement Campaign

Idaho National Laboratory is active in the development of pyroprocessing technology and has current programs exploring spent nuclear fuel separations using molten salt technology. Measurements are planned at the Materials and Fuels Complex Analytical Laboratory (AL) to evaluate laboratory NDA of small process samples, and at the Hot Fuel Examination Facility (HFEF) to evaluate on-line measurements. The questions that will be considered by this measurement campaign include:

1. What are the observable signatures of fissile material content available with each measurement technology?
2. How precisely can these signatures be quantified?
3. How can salt samples with fissile material and fission products be handled in a laboratory to achieve optimized NDA measurement performance?
4. What are the operational limitations of each measurement technology in a high-background, high-count rate facility environment?

The AL routinely analyzes a wide range of samples from advanced nuclear fuel cycle development work at Idaho National Laboratory, and includes destructive and traditional nondestructive analysis capabilities. Through separate projects, a microcalorimeter gamma spectrometer is currently being built for deployment to the AL by mid-FY21. This new instrument will be used alongside traditional NDA technologies to measure available samples from electrochemical separations relevant to on-line separations in liquid-fueled MSRs. An important outcome of this measurement campaign will be to validate the performance of advanced and traditional NDA technologies with the same relevant samples handled in a laboratory environment. In addition to the gamma-ray and neutron technologies summarized in this report, advanced CdZnTe gamma-ray systems and other spectroscopic and neutron detection technologies will be considered.

HFEF can provide measurement opportunities both in and adjacent to the hot cell where intensely radioactive spent fuel materials are available. Prior testing of the HDND at HFEF demonstrated the capabilities of this facility for evaluation of NDA technologies in an operational environment [14]. Figure 11 shows an example of a germanium detector installed at HFEF to view items inside a hot cell through a collimator. HFEF is a highly subscribed facility, especially due to COVID-related operational restrictions. Contingent on approvals, it may be possible to perform a side-by-side comparison of traditional and advanced NDA technologies at HFEF.

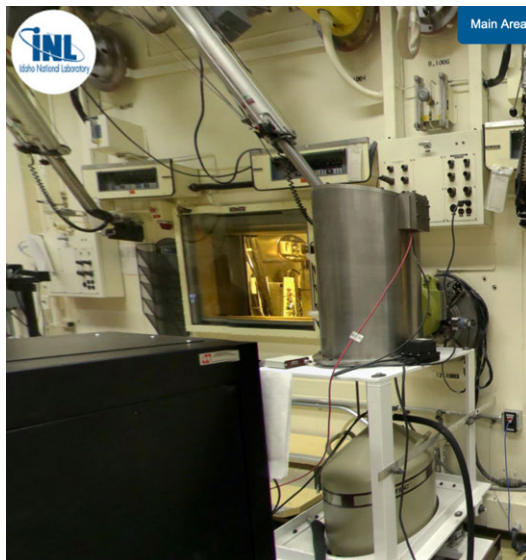

Figure 11: Germanium detector installed at Idaho National Laboratory's Hot Fuel Examination Facility (HFEF) used to perform post-irradiation examination on irradiated fuel rods and specimens. The detector views items inside the hot cell through a collimator which reduces gamma flux and has a BGO guard detector to reduce effects from Compton scattering.

6. Summary

In FY20, a systematic approach was developed for the evaluation of NDA measurement capabilities and applied to a measurement campaign at Los Alamos National Laboratory focused on gamma-ray measurement technology. Measured materials from a spent fuel separation process at Argonne National Laboratory were chosen to evaluate limits of quantifying fissile material signatures in the presence of varying concentrations of fission products and actinides. Both HPGe and microcalorimetry are capable of quantifying important nuclides, and each have unique advantages due to efficiency or energy resolution. Results suggest that direct quantification of important actinides in fuel salt may be possible by NDA for a sampling loop in an operating MSR or for salt samples. Further work including measurements of additional irradiated fuel materials and comparison with TRANSFORM model results is required to test this hypothesis. Initial testing of the miniHDND in preparation for FY21 measurement activities has been completed. Plans for neutron measurement campaigns at LANL and joint measurements to begin in FY21 at Oak Ridge National Laboratory and Idaho National Laboratory on increasingly representative materials have also been completed.

7. Acknowledgements

We gratefully acknowledge Laura Maggos, Mark Williamson, and colleagues at Argonne National Laboratory for providing the samples used in the LANL gamma measurement campaign. This work is supported by the U. S. Department of Energy, Office of Nuclear Energy, Advanced Reactor Safeguards program.

8. References

1. D. Holcomb, "Module 2: Overview of MSR Technology and Concepts", presentation for US Nuclear Regulatory Commission, 2017.
<https://gain.inl.gov/MSR%20Training%20Module/Module2-OverviewofMSRTechnologyandConceptsML17331B114.pdf>
2. M. S. Greenwood, B. R. Betzler, A. L. Qualls, J. Yoo and C. Rabiti, "Demonstration of the Advanced Dynamic System Modeling Tool TRANSFORM in a Molten Salt Reactor Application via a Model of the Molten Salt Demonstration Reactor," *Nuclear Technology*, 2019.
3. Meier, D., Casella, A., Abrecht, D., Woodring, M., Chatterjee, S.D., Schwantes, J.M., Sexton, L., Coble, J., & Shoman, N., "Multi-isotope process (MIP) monitor deployment at H-Canyon", GLOBAL 2015 Proceedings, 2015.
4. M. Croce, D. Becker, D. Bennett, M. Carpenter, J. Gard, K. Koehler, J.A.B. Mates, D. Mercer, N. Ortiz, D. Schmidt, D. Swetz, A. Tollefson, A. Wessels, M. Yoho, D. Vo, J. Ullom, "Advances in Microcalorimeter Gamma Spectroscopy", Proceedings of the INMM Annual Meeting, 2020.
5. M. P. Croce, K. E. Koehler, M. D. Yoho, S. E. Kossmann, S. E. Garner, M. W. Rabin, D. T. Becker, N. J. Ortiz, J. A. B. Mates, J. D. Gard, D. A. Bennett, J. N. Ullom, "Practical Microcalorimeter Spectrometers", Proceedings of the INMM Annual Meeting, 2019.
6. D. Reilly, N. Ensslin, H. Smith, Jr., and S. Kreiner, Passive Nondestructive Assay of Nuclear Materials, Los Alamos National Laboratory Technical Report LA-UR-90-732 (1991).
7. D. Henzlova and H.O. Menlove, High-Dose Neutron Detector Development, Los Alamos National Laboratory report, LA-UR-15-27500, 2015.
8. EFC Company <https://gammaraydetectors.com/>
9. Mirion Technologies (Canberra) Inc. <https://www.mirion.com/products/lege-low-energy-germanium-detector>
10. D. Henzlova, H.O. Menlove, Final Report on High Dose Neutron Detector for FY18, Los Alamos National Laboratory Technical Report, LA-UR-18-29899, 2018.
11. J.B. Marlow, M.T. Swinhoe, H.O. Menlove, C.D. Rael and M.R. Newell, Advanced Verification for Inventory Sample System (AVIS) Manual, Los Alamos National Laboratory Technical Report, LA-UR-11-07086, 2011.
12. M.C. Miller, H.O. Menlove, A. Abdel-Halim, B. Hassan, A. Kestleman, The Improved Inventory Sample Counter INVS Mod III, Los Alamos National Laboratory Technical Report, LA-12112-M, 1991.
13. S. K. Smith, S. Croft, A. Nicholson, G. Nutter, "High-resolution Gamma Spectroscopy Measurements of Pressurized Water Reactor Spent Nuclear Fuel Rods", Oak Ridge National Laboratory Technical Report, ORNL/SPR-2017/535, 2017.
14. D. Henzlova, H.O. Menlove, J. Sanders, A. Williams, Report on MPACT Deliverable M2FT-18LA040106031 (HDND field test with mixed neutron gamma field), Los Alamos National Laboratory Technical Report, LA-UR-18-24696, 2018.