

Demonstrating Autonomous Architectures for Microreactors Under Prototypic Conditions in PUR-1

2026 Microreactor Program Review

Stylianos Chatzidakis

Assistant Professor

School of Nuclear Engineering

Purdue University

March 2026

West Lafayette, IN

Team Info

- **Purdue**

- Stylianos Chatzidakis (Assistant Professor and Associate Reactor Director, SRO)
- True Miller (Reactor supervisor, SRO)
- Brian Jowers (Electronics/I&C reactor staff, RO)
- V. Theos, Z. Dahm, K. Vasili, K. Gkouliaras, W. Richards (Grad students)



- **UNM**

- Mohamed El-Genk (Distinguished and Regents' Professor)
- Timothy Schriener (Research Associate Professor)
- Ahmad Shaheen (Grad student)



- **Collaborators**

- Robert Ammon (Curtiss-Wright)
- Rick Vilim (ANL)



- **TPOC: Ben Baker (INL)**



Goals & Objectives

Goal: Experimentally validate semi-autonomous control and demonstrate its use in PUR-1 and VSLIMM.

Objectives:

1. Develop a modular digital twin platform with various levels of automation using a remote workstation with AI/ML algorithms
2. Train AI/ML using physics-based models and real-time digital operation data collected from PUR-1
3. Perform testing and evaluate performance

Towards a Real-Time Cyber-Physical Digital Twin



PUR-1

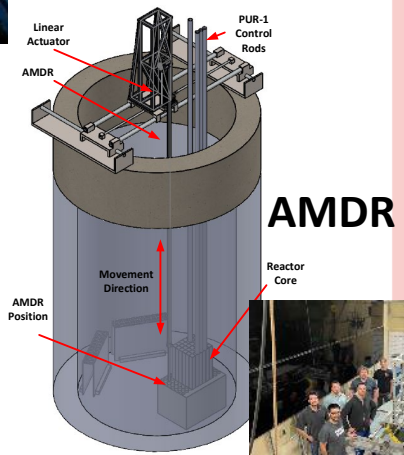

AMDR

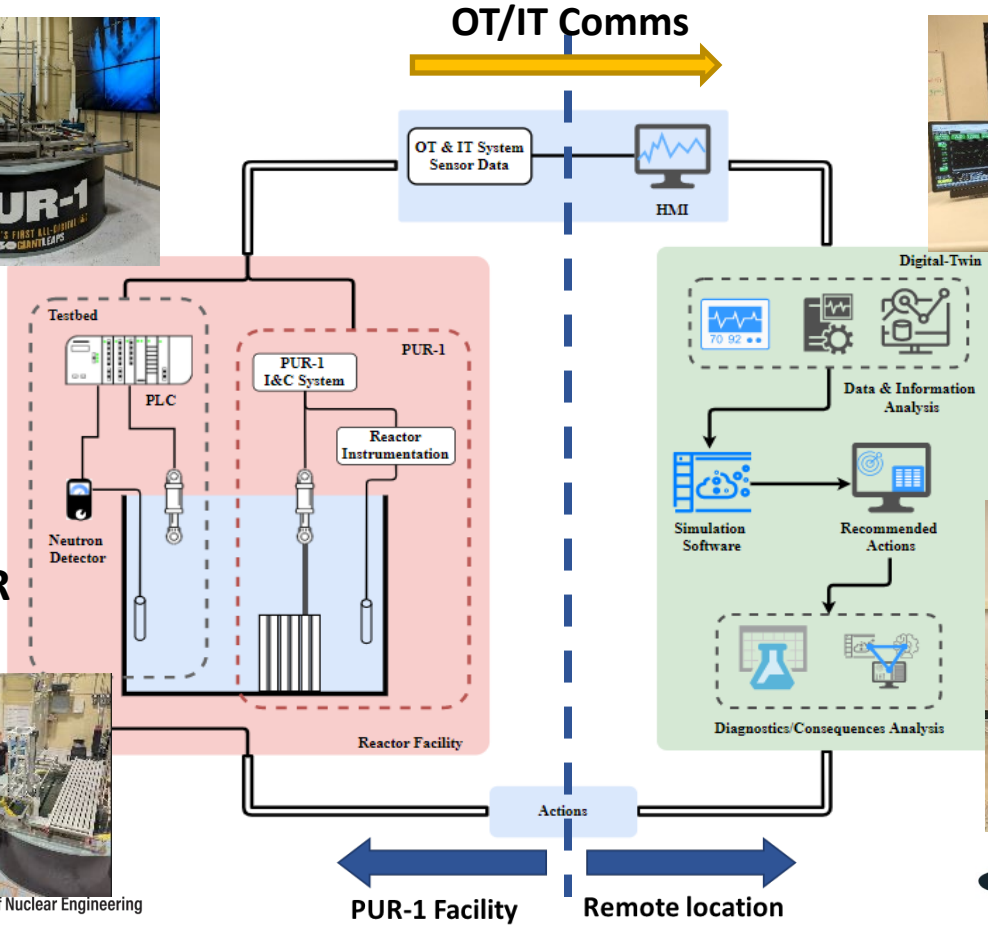
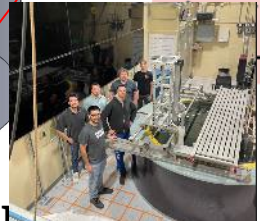

PUR-1 Facility

Remote location

OT/IT Comms

OT & IT System Sensor Data

HMI

Digital-Twin

Data & Information Analysis

Simulation Software

Recommended Actions

Diagnostics/Consequences Analysis

Actions



RMSS

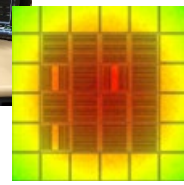

Control rack



Digital/Cyber Remote Station

RTP 3000 TAS N+
Nuclear grade PLC
16 CH AI/AO
32 CH DI/DO

Field
Programmable
Gate Array

Power
distribution
unit

Actuator control

IT Monitoring

R-TIME GUI

Stats:
2000 parameters
1kHz sampling

OpenMC
COMSOL
OpenFOAM

Real-time diagnostics

Siemens S7 PLC

UPS APC/1500

To GPU

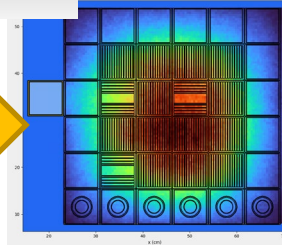

Datasets for Benchmarking

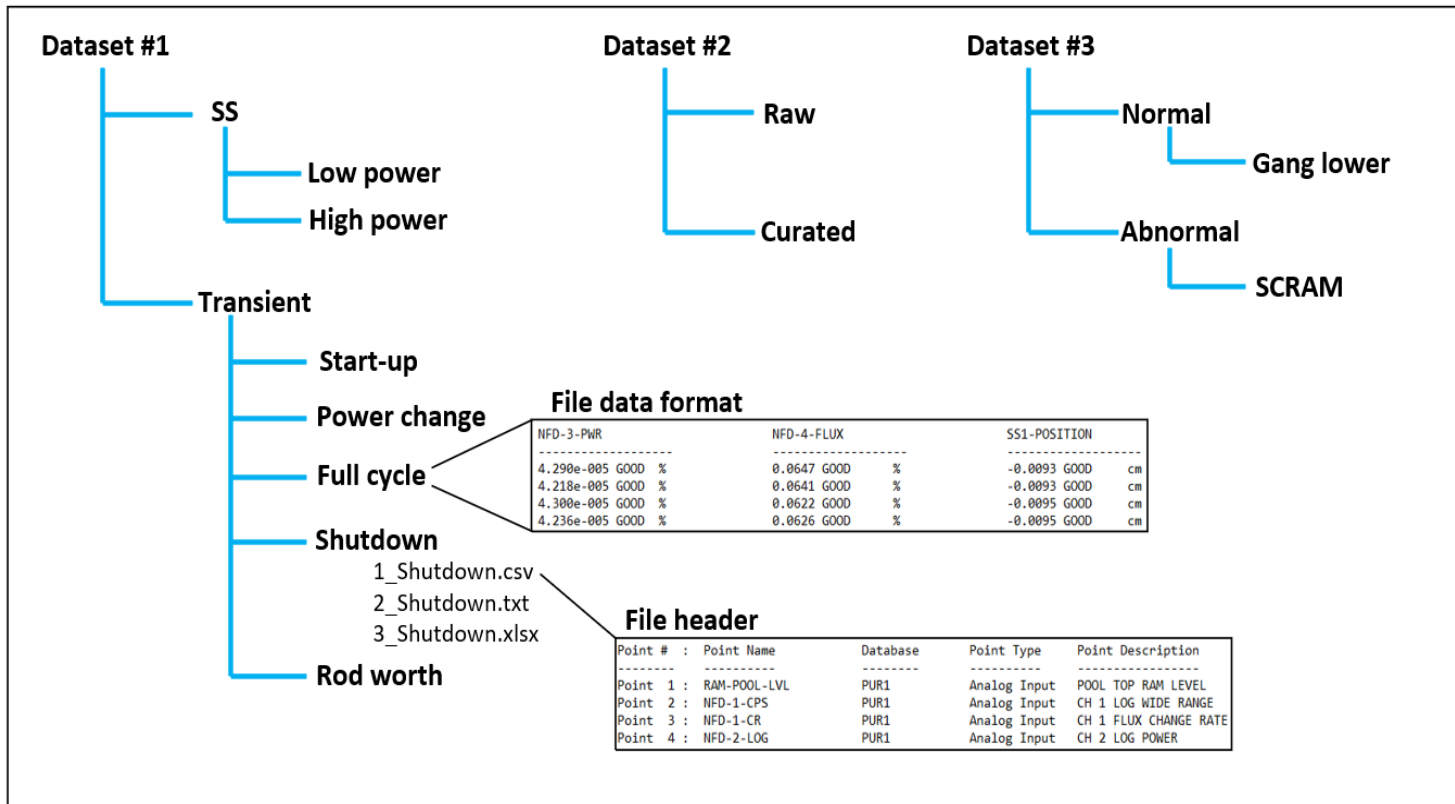

Modeling and Simulation

PUR-1

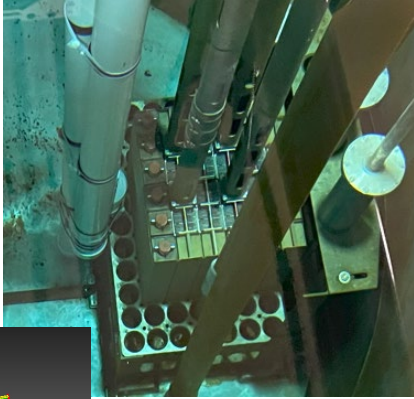
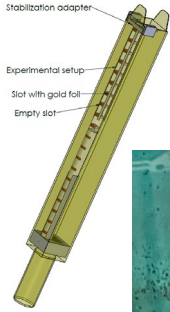

Neutronics + PKE Models

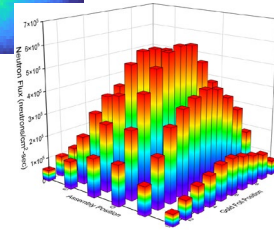
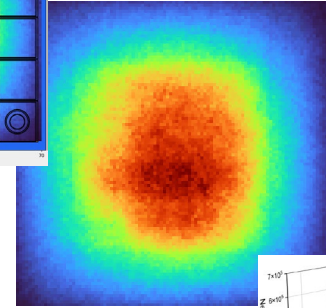
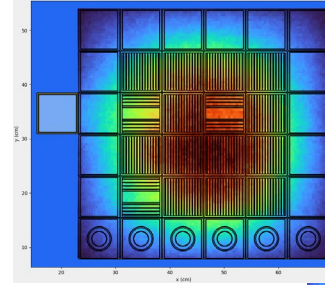

CAD Model

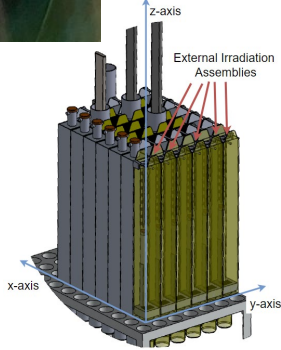
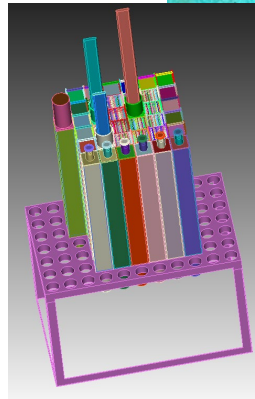

TH Models

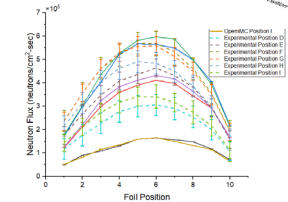
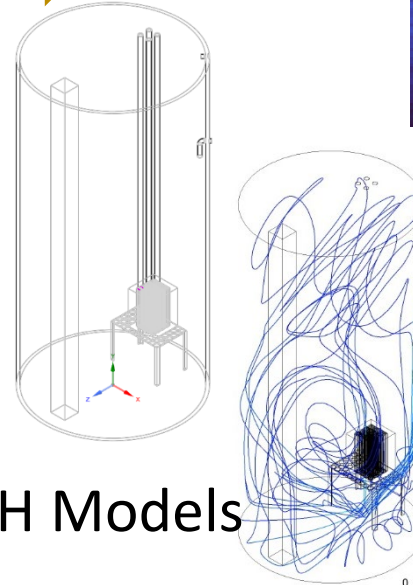

Network Communications Model

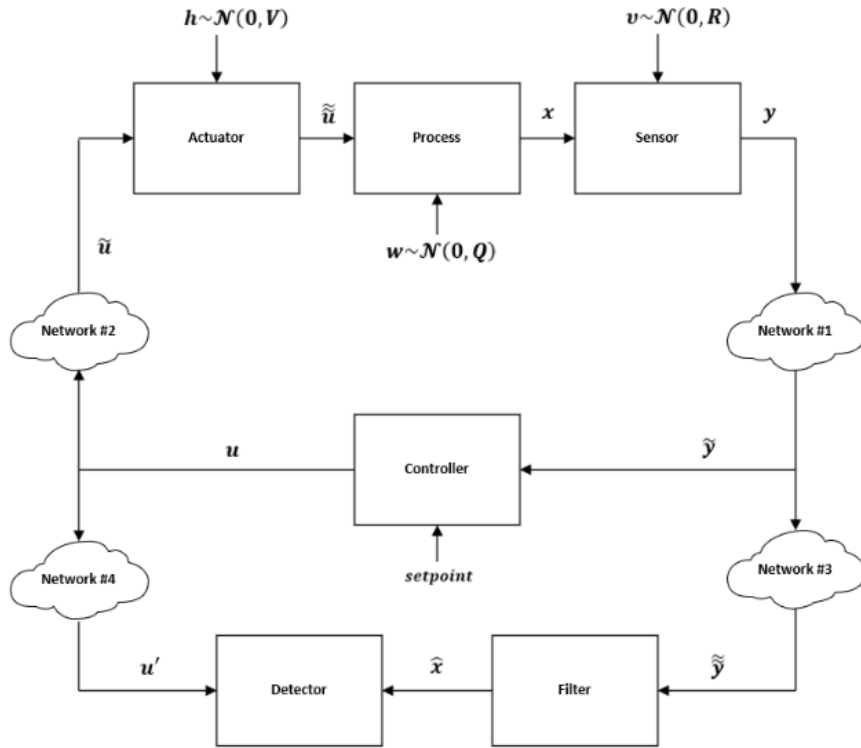

Sensor

$$y_k = Cx(t_k) + v_k, v_k \sim \mathcal{N}(0, R)$$

Network

$$\tilde{y}_k = \begin{cases} y_{k-d_k} + h_k^{(net)}, & w.p. 1 - p_l \\ \tilde{y}_{k-1}, & w.p. p_l \text{ (hold)}, \end{cases}$$

Latency

$$t_{net} = t_{ser} + t_{prop} + t_{queue} + \sum t_{dev}$$

Controller

$$u_k = K_p e_k + K_i \sum_{j=0}^k e_j + K_d \frac{e_k - e_{k-1}}{\Delta t}$$

Actuator

$$r_{k+1} = r_k e^{-T_s/\tau_{act}} + \tilde{u}_k^{cmd} (1 - e^{-T_s/\tau_{act}})$$

Command

$$u_k^{cmd} = sat(r_{k-1} + u_k, r_{min}, r_{max})$$

Network Communications w/ Adversary Model

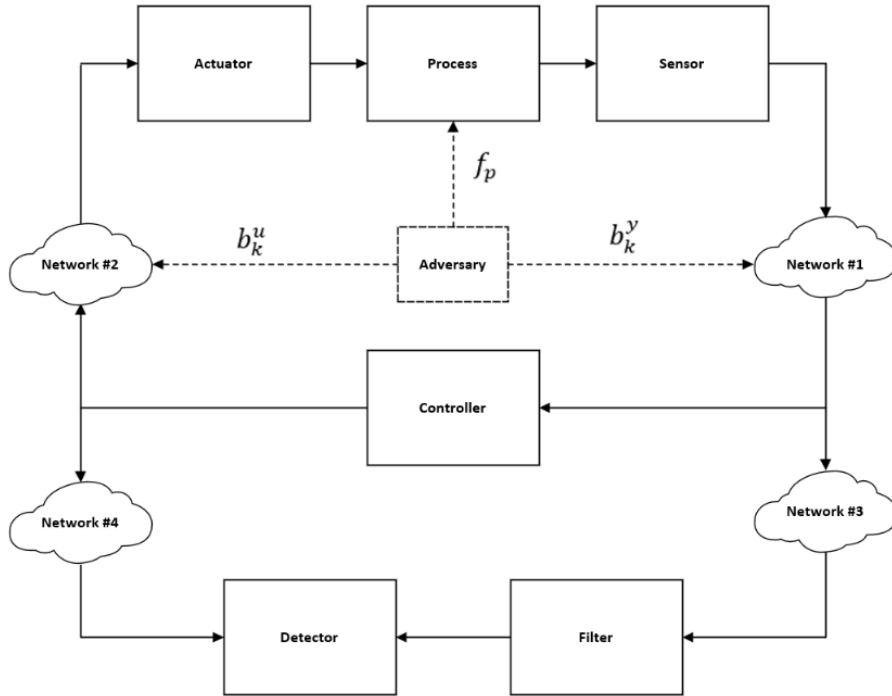

Fault vector

$$f_k = [f_k^p \ f_k^a \ f_k^c \ f_k^s]^T$$

$$y_k = Cx(t_k) + v_k + F_k^s f_k^s, v_k \sim \mathcal{N}(0, R)$$

Attack vector

$$a_k = [b_k^y \ b_k^u]^T$$

$$\tilde{y}_k = y_k + \Gamma_k^y b_k^y$$

$$\tilde{u}_k = u_k + \Gamma_k^u b_k^u$$

Semi-autonomous Architecture

Completed

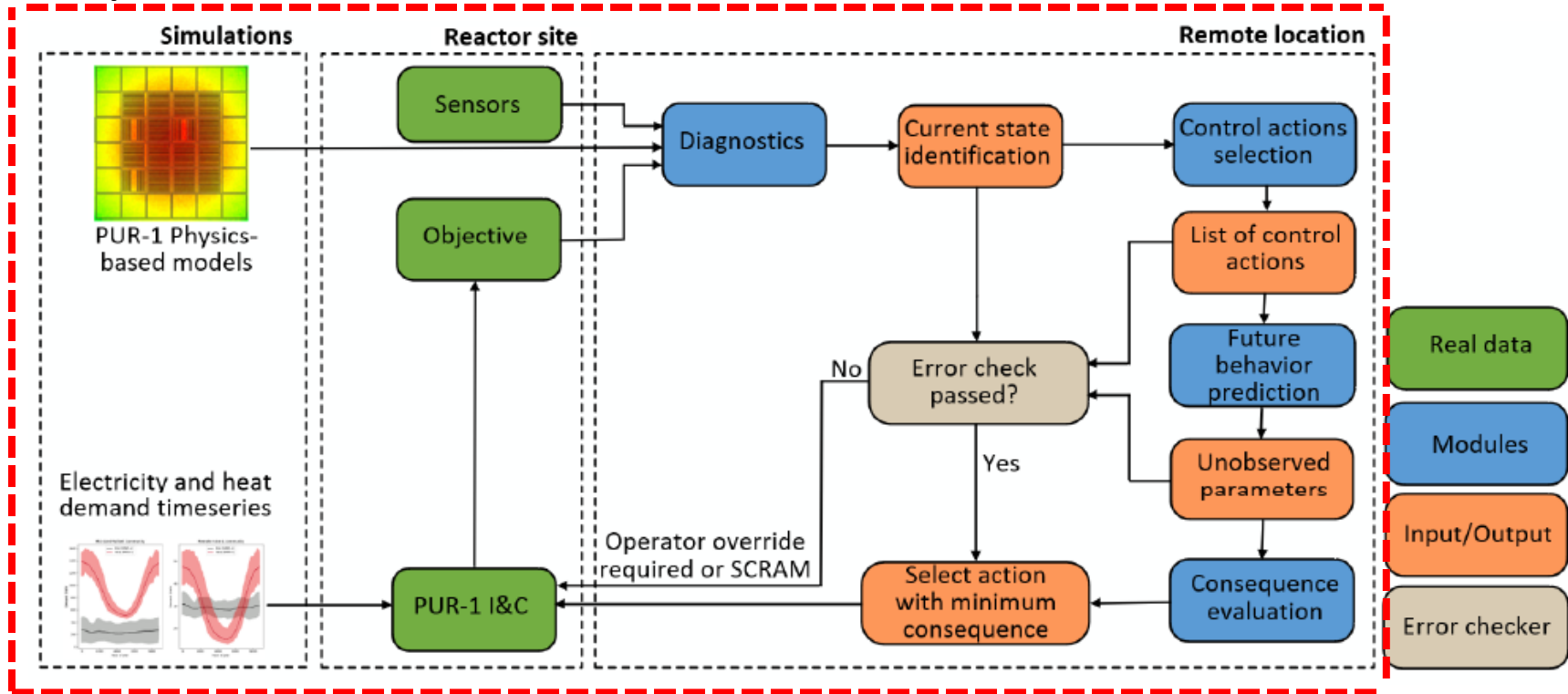

Semi-autonomous Architecture

- **Diagnostics**
 - Random Forest to identify state ID, e.g., startup, shutdown, constant power etc.
 - Autoencoders to reconstruct radiation sensor data, LSTM and GRU to reconstruct reactor power, and XAI for anomaly detection
- **Control Actions Selection**
 - Rule-based limitation on control action space
- **Future behavior prediction**
 - Transformer with future covariates incorporated from selected control actions
- **Consequence evaluation**
 - Fuzzy logic system to assign score to each forecasted control action, then highest score action is chosen
 - Actions which exceed safety constraints are ruled out entirely

Performance Evaluation - Load Following

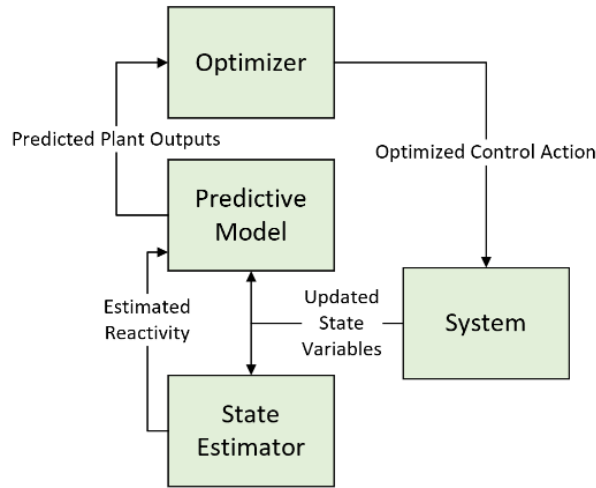

$$\min_{u_0:N_c} \sum_{k=0}^{N_p} (|\hat{n}_k - n_{set}| + c_1(u_k - u_{k-1})^2 + c_2(\hat{n}_k - \hat{n}_{k-1})^2)$$

$$\text{subject to: } \hat{x}_0 = x_0,$$

$$n_{lb} \leq \hat{n}_k \leq n_{ub} \forall k = 0, \dots, N_p$$

$$u_{lb} \leq u_k \leq u_{ub} \forall k = 0, \dots, N_p$$

$$|u_k - u_{k-1}| \leq \Delta u_{ub}$$

$$\hat{n}_k - \hat{n}_{k-1} \leq \Delta n_{ub}$$

$$\hat{x}_{k+1} = f(\hat{x}_k, u_k), \forall k = 0, \dots, N_p$$

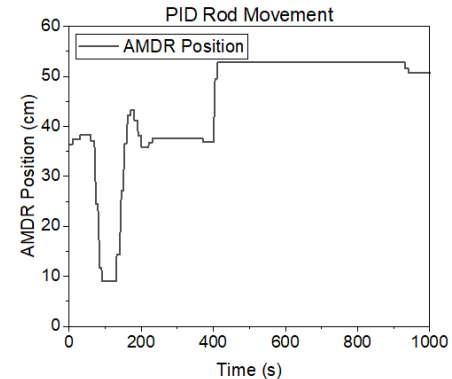
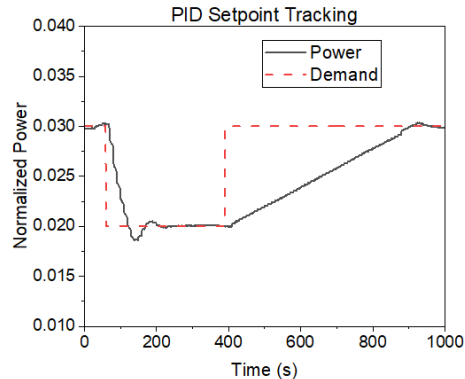
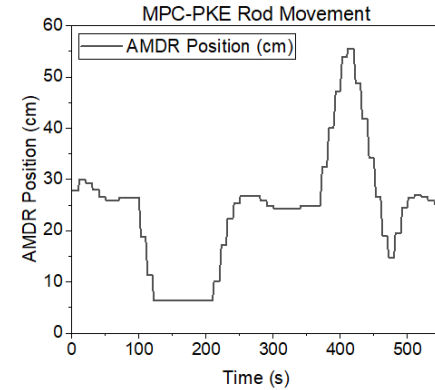
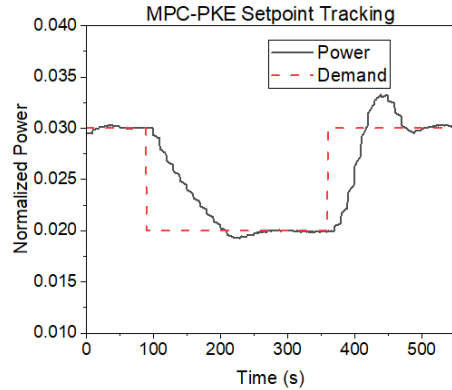

Performance Evaluation – Bias Injection Attack

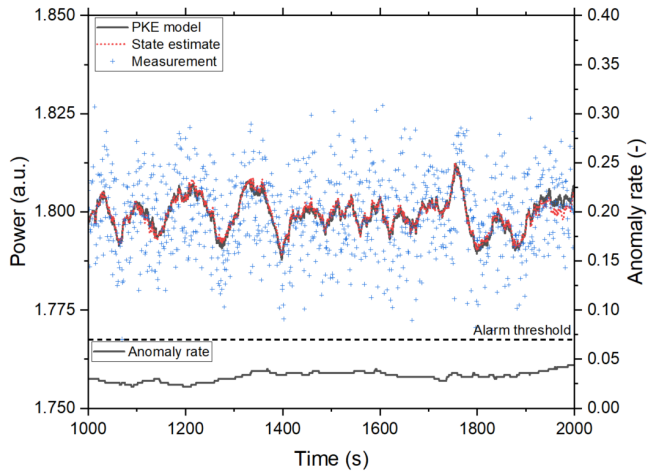

Normal conditions

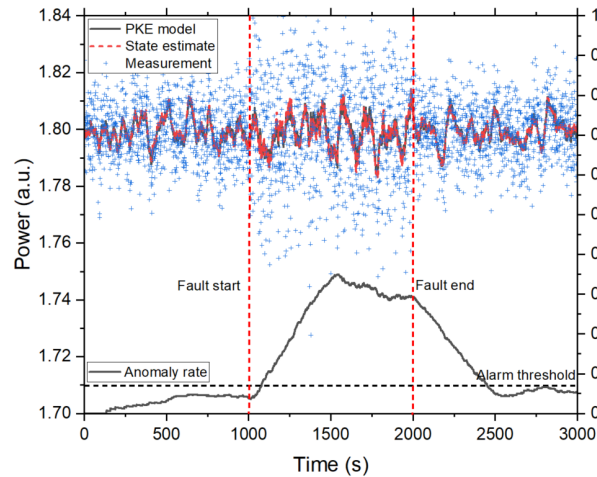

Increased sensor noise

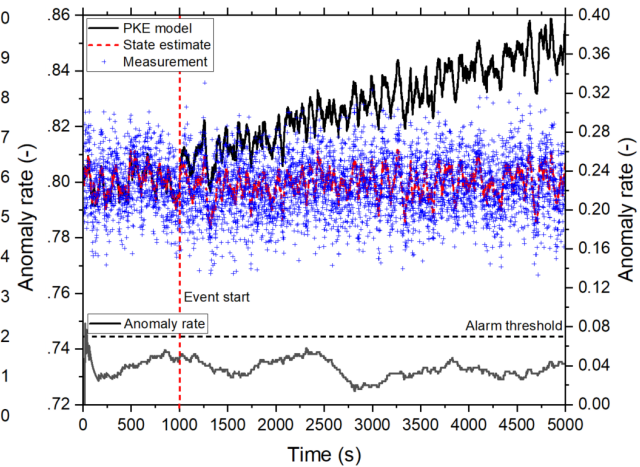

Low level bias injection

Performance Evaluation – Cyber Event Detection

AI/ML can be trained with data extracted from normal and abnormal system states

Maximum achievable performance depends strongly on algorithm and data available

Amount of abnormal data available can be a limiting factor

SHAP can identify source of FDI

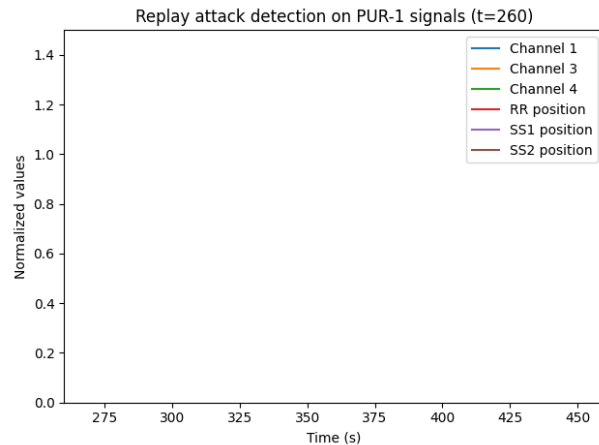
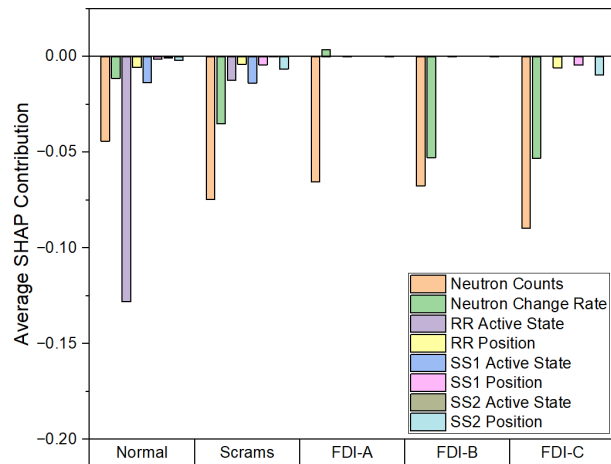

Acknowledgements

This research is being performed using funding received from the DOE Office of Nuclear Energy's Nuclear Energy University Programs under contract DE-NE00009268.

We also thank Rick Vilim from ANL, and John Jackson and Ben Baker at INL for fruitful discussions and expert input.



Questions?