

March 3, 2026

Ryan Davis
Ryan.Davis@inl.gov

Tim McJunkin
Timothy.McJunkin@inl.gov

INL Nuclear Powered Microgrid Team
NPM@inl.gov

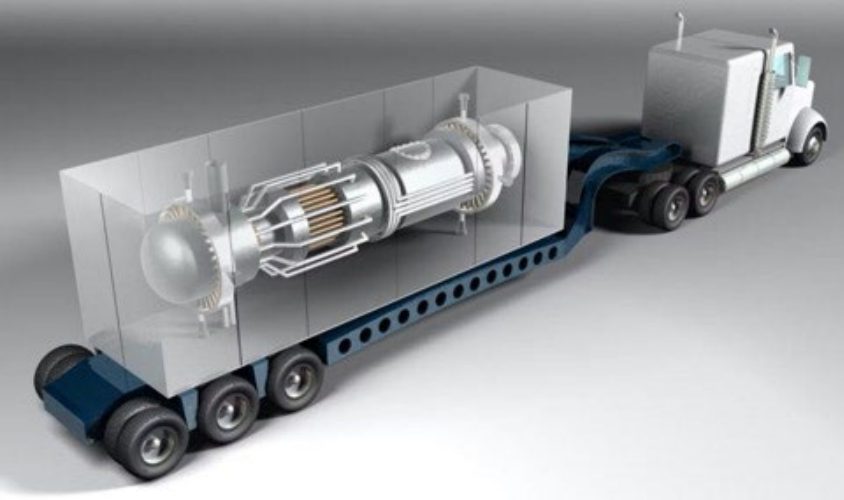

Nuclear Powered Microgrids

Winter Microreactor Program Meeting

Battelle Energy Alliance manages INL for the
U.S. Department of Energy's Office of Nuclear Energy



Traditional Microgrids Applications

- Island-able electricity
- Backup power
- Combined heat & power

- Diesel or natural gas power source
 - Manage grid voltage & frequency
 - May be inefficient

ELECTRICITY

RTAC

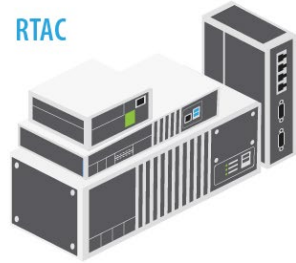

Frequency/Voltage/Grid services

GRID INTERACTION CONTROL AND ISLANDING

RELAY



Electricity protection

MICROGRID-
IN-A-BOX



Battery energy
storage system



Islanding and Grid Connection

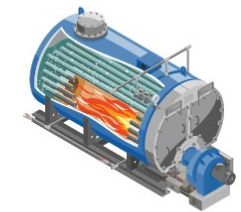

Additional Energy Sources



Combined Heat and Power
(CHP) Applications



Electricity Applications



Grid Services

Stepping up microgrid capabilities with storage

- Energy storage
 - Optimize use of generation
 - Manage variable energy resources
- Economic optimization with bulk electricity markets
- Provide services to the distribution and transmission system

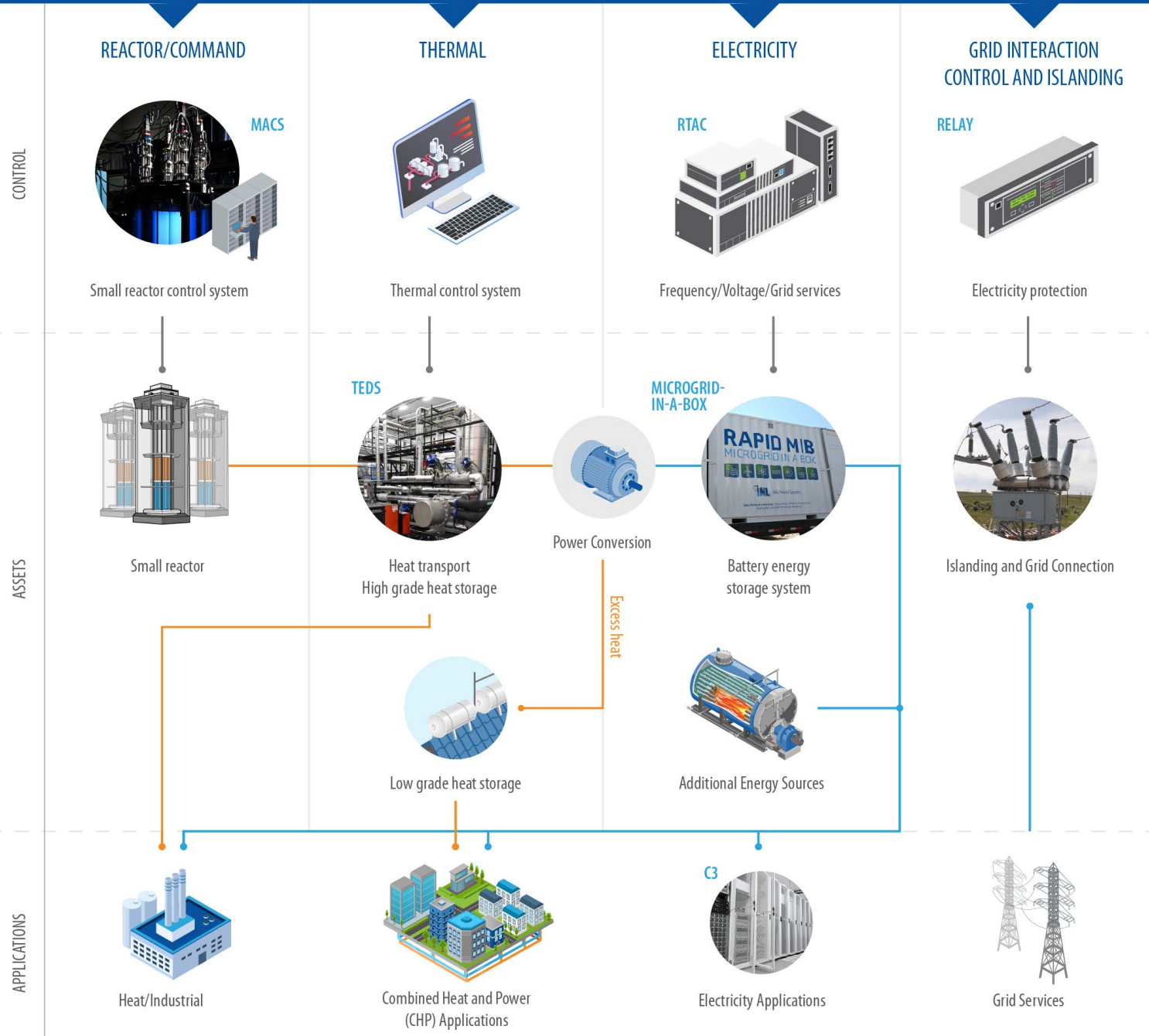

Nuclear Powered Microgrids

- Benefits
 - High grade heat applications
 - Not dependent on continuous fuel supply
- Challenges
 - More complex systems/needed coordination
 - “Priceless” first of kind components
- Approach
 - Optimize choice of components based on applications
 - Reduce risk through digital engineering and real-time simulation/emulation

Facilities to Reduce Deployment Risk Energy Systems Integration Laboratory

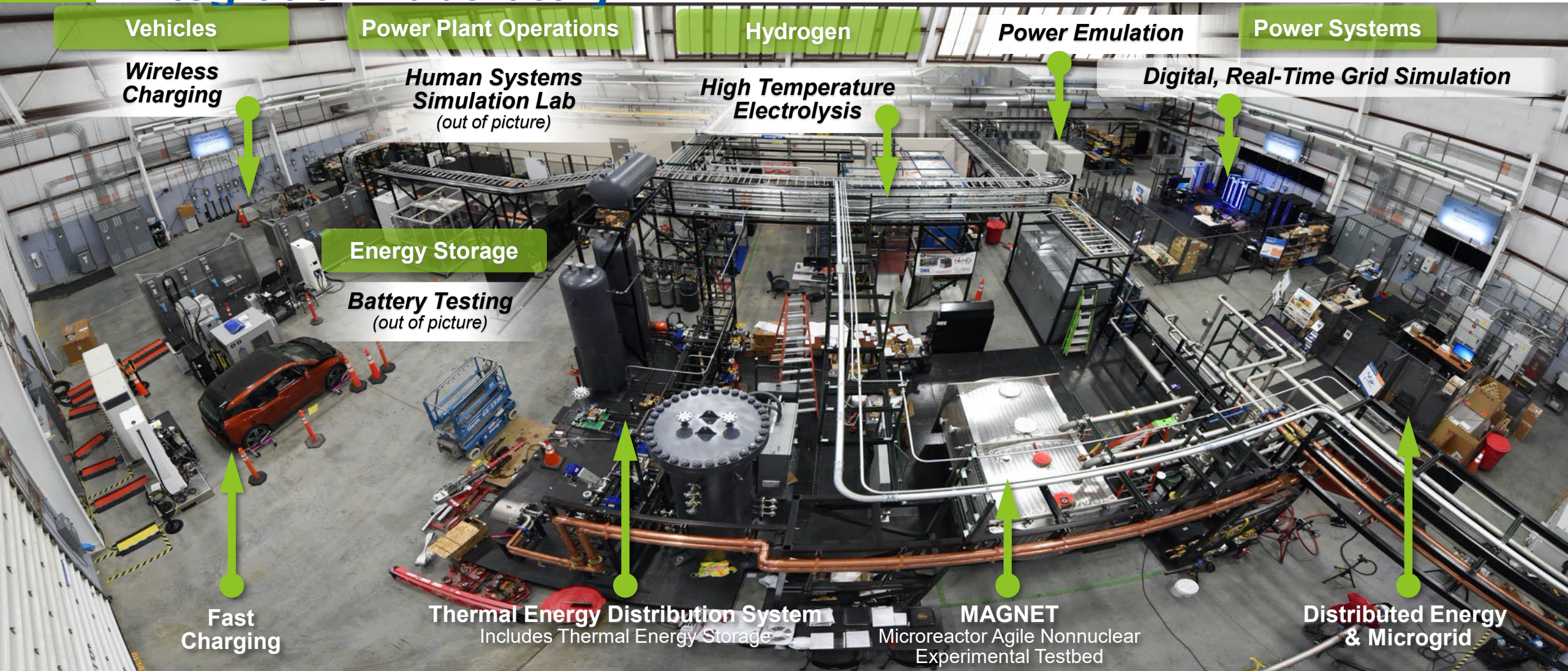

Vehicles

Wireless Charging

Power Plant Operations

Human Systems Simulation Lab
(out of picture)

Hydrogen

High Temperature Electrolysis

Power Emulation

Digital, Real-Time Grid Simulation

Power Systems

Energy Storage

Battery Testing
(out of picture)

Fast Charging

Thermal Energy Distribution System
Includes Thermal Energy Storage

MAGNET
Microreactor Agile Nonnuclear
Experimental Testbed

Distributed Energy & Microgrid

Simulation and Grid Emulation: Power & Energy Real-Time Laboratory

Opal RT, FPGA Development Environment
(IEEE 1394 and MIL 1553)

High Performance Computing (~1800 cores)

Controllers
(Siemens, SEL RTAC)

100+ RISC-based programmable cards for emulating hardware devices
(Electric Vehicles, Wind Turbines)

Typhoon HIL
for Testing Advanced Power Electronics

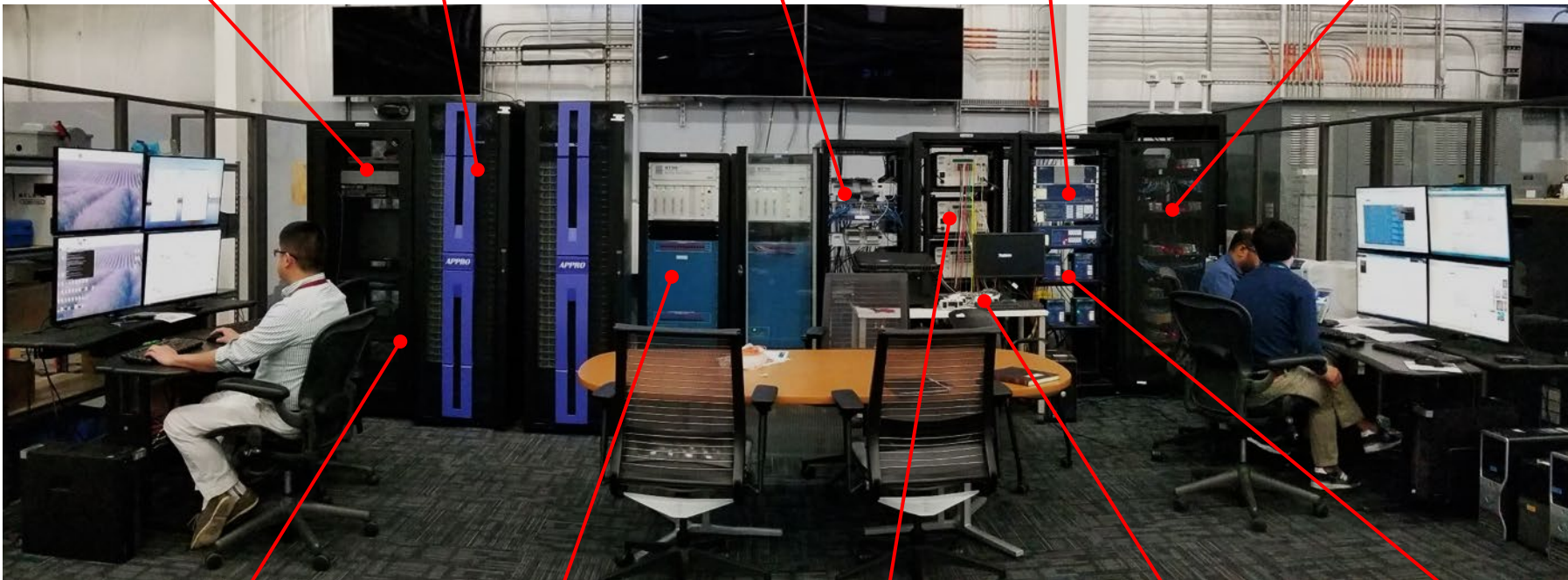

Linux Servers for communication layer, Real-time Data Analytics

Real-Time Digital Simulator

Programmable V & I-Amplifiers

Micro-PMUs

Protection Relays



4 RTDS NovaCor (up) and 540kW Amatech grid emulator

Advanced Microgrid Testbed

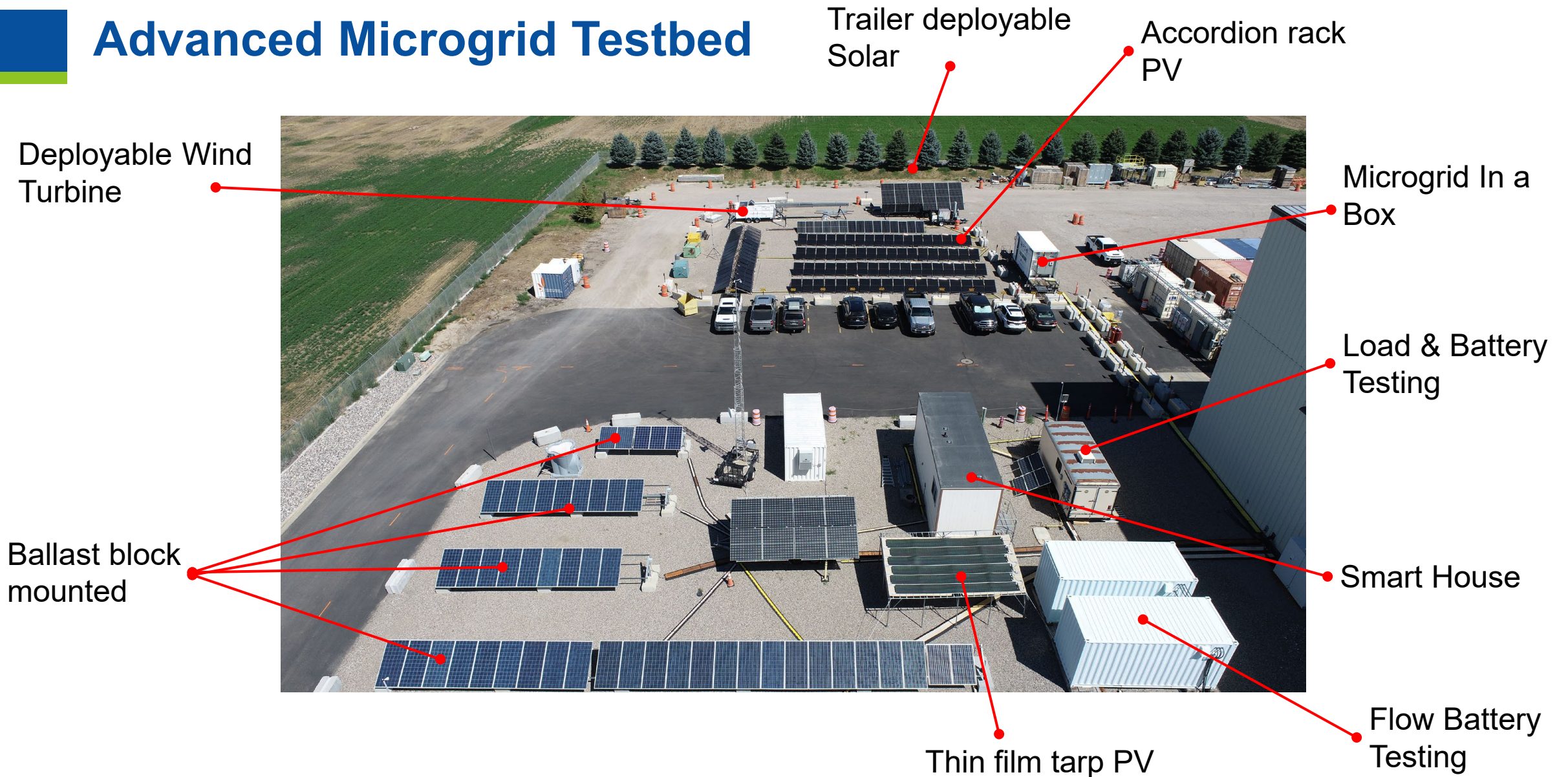

All rapidly deployable photo voltaic inverter-based resource

RAPID-MIB, the Microgrid-in-a-Box

- This is a first-of-a-kind system for portable, medium-high energy density power grid storage applications with a size that can power a 125kW-250kW sized commercial/end-user building/facility, for multiple hours, with switchable power ratings between 415/230VAC, 50Hz, three-phase to 480/277VAC, 60Hz three-phase, and including advanced controls for specified functions during both grid-tied and islanded operations that are suitable for military or commercial/utility applications.
- The control mode features available in this system are newly released, and allow for stacked mode uses and droop settings (or fast frequency-Watt and/or Volt-Var) adjustments during operations with communications and commands from advanced secondary/tertiary control systems.
- System can stay in voltage-source in most applications, or switched to P-Q or other modes as needed.
- Portable and deployable energy blocks are connected into and managed by the microgrid controls system as needed/available. These can include solar, wind, micro-nuclear, fueled resources, hydrogen-based, etc.
- RAPID-MIB stands for Relocatable/ Resiliency Alternative Power Improvement for Distribution – Microgrid In a Box



Kuwait: Successful field implementations

- Three successfully completed field implementations
 - USARCENT Operational Energy program managed through INL.
 - Two separate military installations in Kuwait.
- The first project: first hybrid microgrid implementation for the US in Kuwait,
 - Advanced inverters, battery storage and specialized solar photovoltaic implementations.
 - Operates with higher than 60% penetration of renewable energy.
 - Operates solely on battery and solar for multiple days in a row.
 - When the battery gets low, the generator is automatically called to supply the load and recharge the battery.

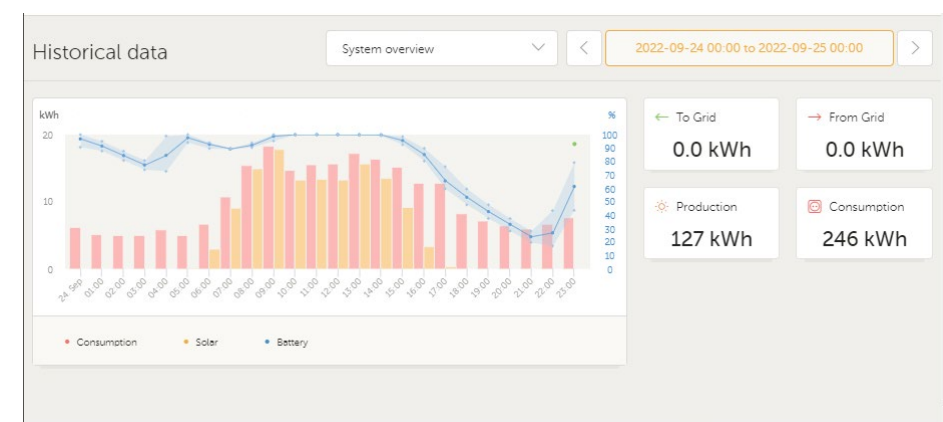

Dugway Proving Ground – ERCIP Microgrid

- Black start automation to sense utility outage and restore power to installation using generator plant
- One feeder on microgrid first distribution level microgrid with UPS functionality
- Seamless transition from Island mode back to utility and Grid Tie mode once utility is restored



Military Application : Energy Dispatch Optimization

Initial Concept

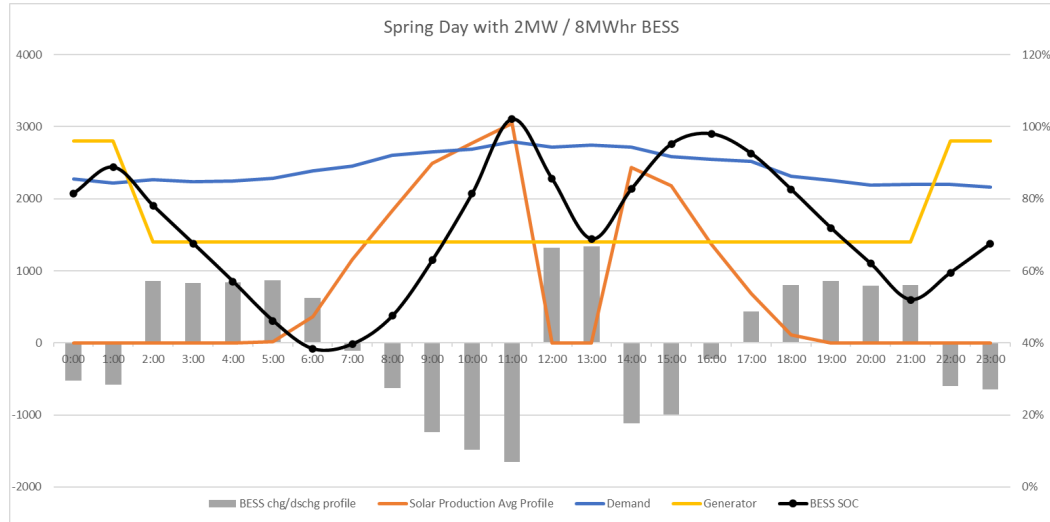

Proposed Concept

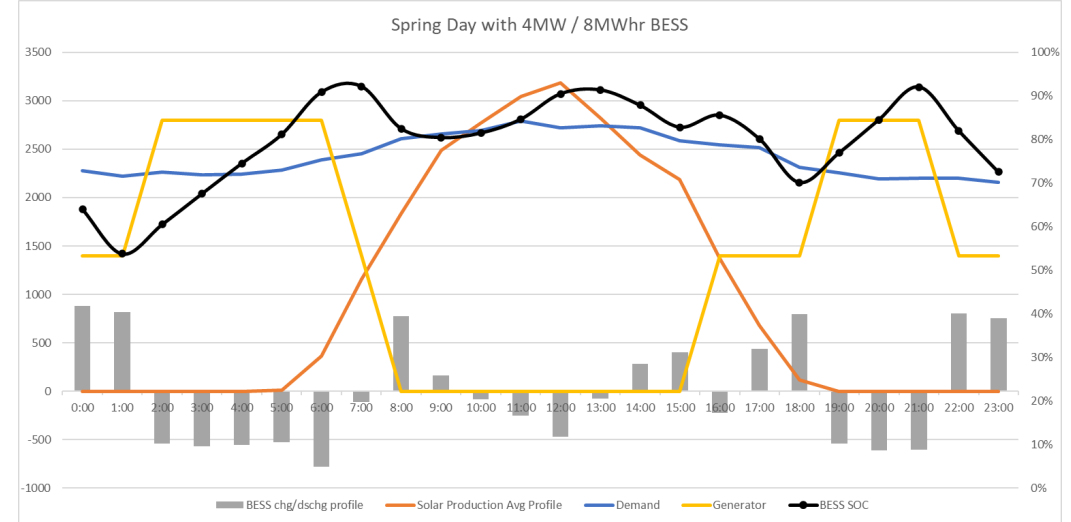

- Analysis of a complex microgrid with initial and proposed BESS & generator sizes in island mode.
- Proposed Concept
 - Capable of operating with generators off
 - BESS state of charge for longevity
 - Optimize for inverter-based generation

Islanded Distribution Grid Black Start: Successful Field Demonstration with Idaho Falls Power

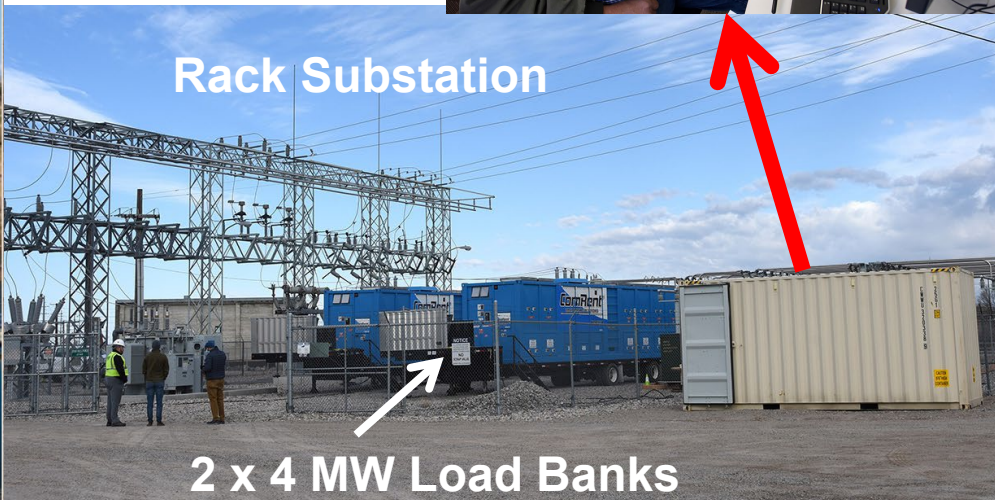
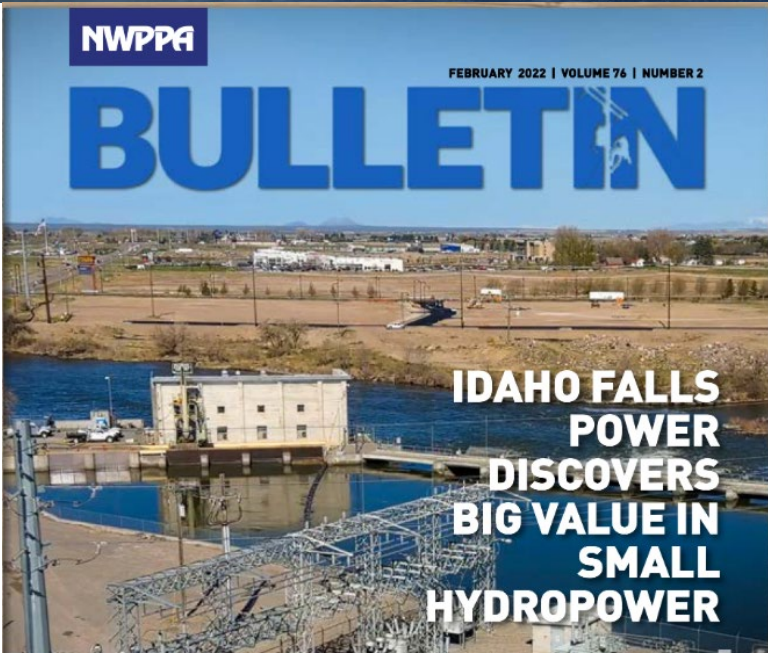
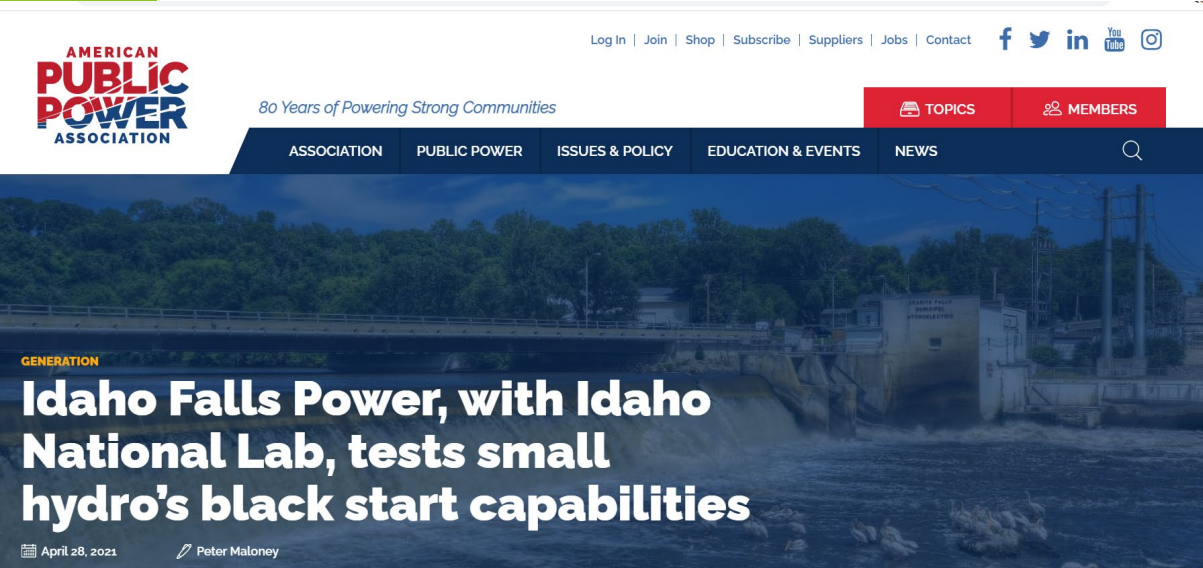

Black Start Field Demonstration of Felt Plant

- Remote site.
- Minimal retrofit to exiting flow control.
- Mobile energy storage support with automatic control.

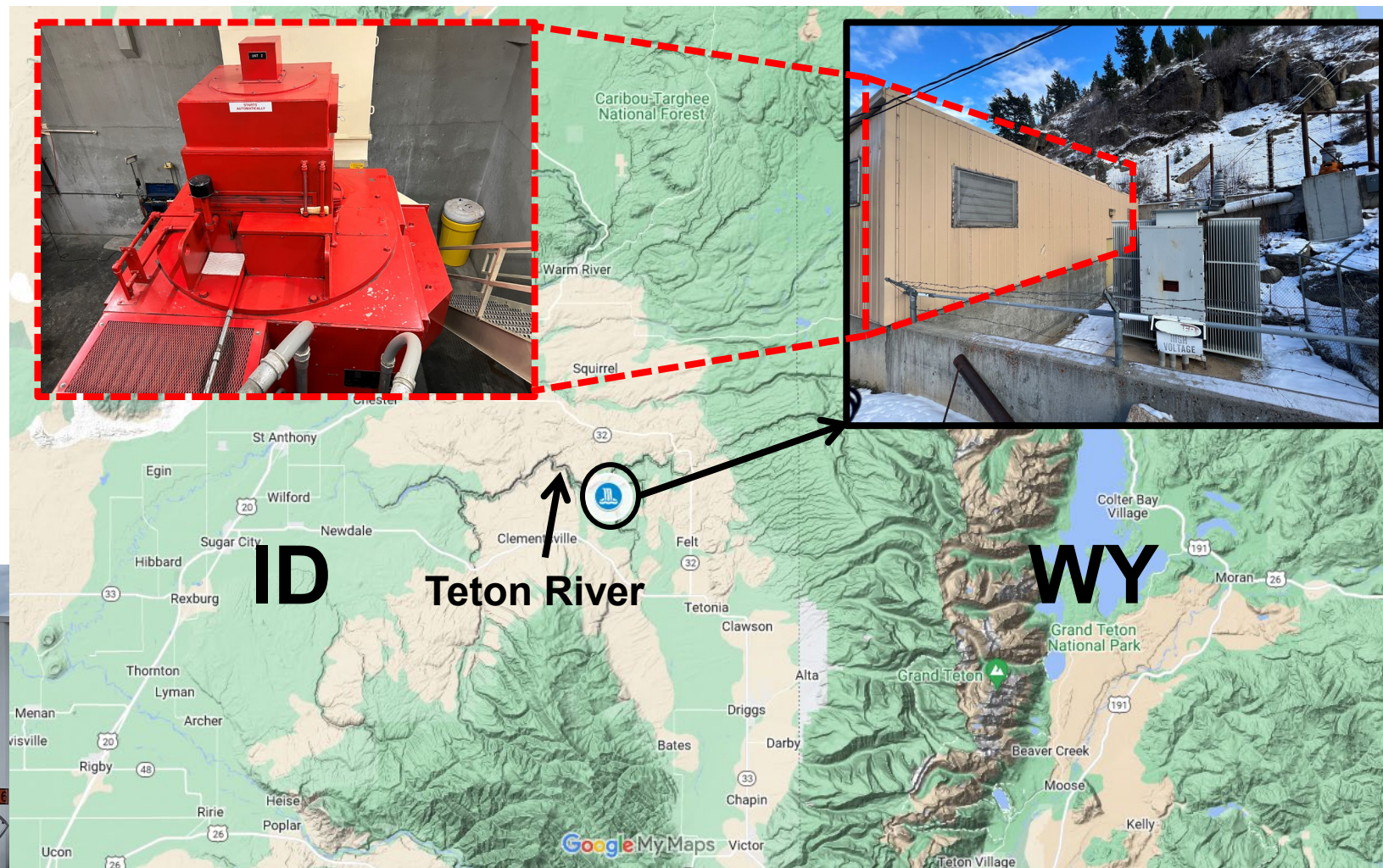

Data Centers in Microgrids Review: Challenges and Opportunities

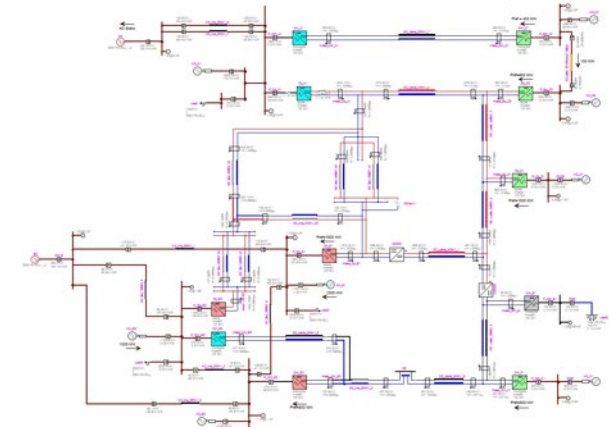
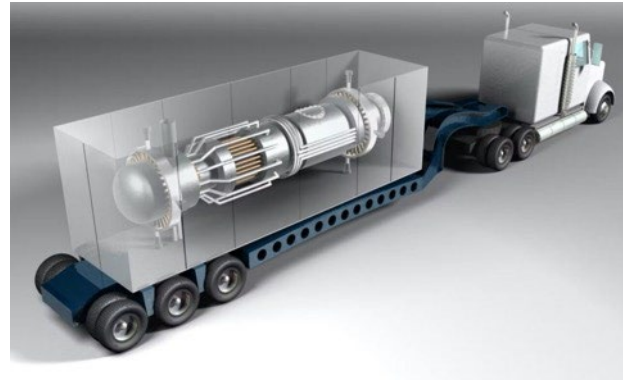
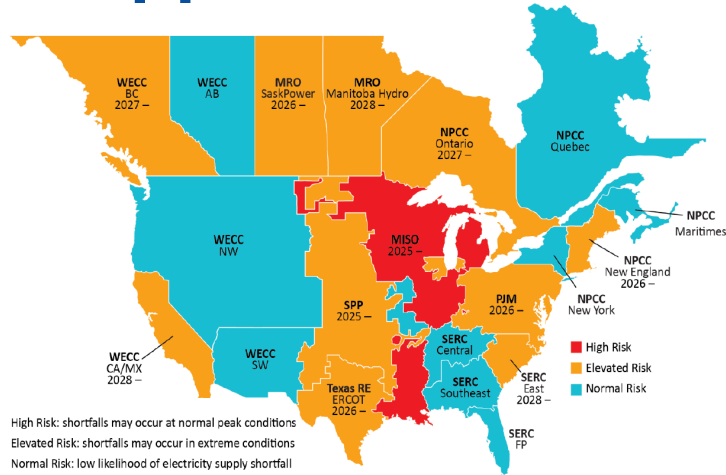

Microgrids for Data Centers

- Grid resource inadequacy
- Stringent reliability and power quality needs
- Relatively stable demand

Modular microgrid solutions with nuclear present an excellent opportunity

Barriers to Implementation

- Load characteristics/ variability
- Frequency and voltage controls with large load
- Harmonics and power factor issues due to DC inverter loads
- Sub-synchronous oscillations
- Impact of voltage-frequency drive (VFD) interfaced motor cooling system

Recommended Analysis

- Accurate demand modeling
- Strategies to collocate generators and data centers
- Ride-through and ramping capabilities
- Power quality and stability evaluation through EMT studies
- Harmonic filters and power factor corrections
- System protection

Aligned NE/OE objectives

- MAGNET power production to a microgrid application (simulated RTDS) demonstration with Microgrid in a Box and data center application (by end of FY26)
- Demonstrate Control Hardware in the loop Microreactor Automatic Control System (NE Developed)/MARVEL RTDS Model with physical Microgrid in a Box and coordinated control system (by end of FY27)
- Demonstration of MARVEL power delivery to microgrid (FY28)
- Foundational Deliverable: testbeds/platforms, staff, and methods to support industry risk buy down for nuclear energy applications (FY28-beyond)

Reducing deployment risk with successive validation of modeling, grid emulation and introduction of physical system components

Control System Hardware



Grid Emulation



Physical Storage
Microgrid control



Physical application



MAGNET – not nuclear

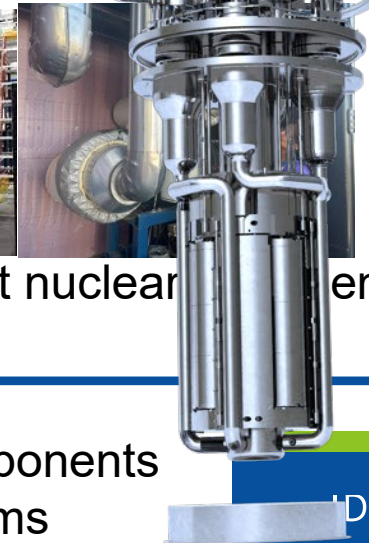

Simulation of reactor

Energy Generation, Storage and Application Models

Real-world components and systems

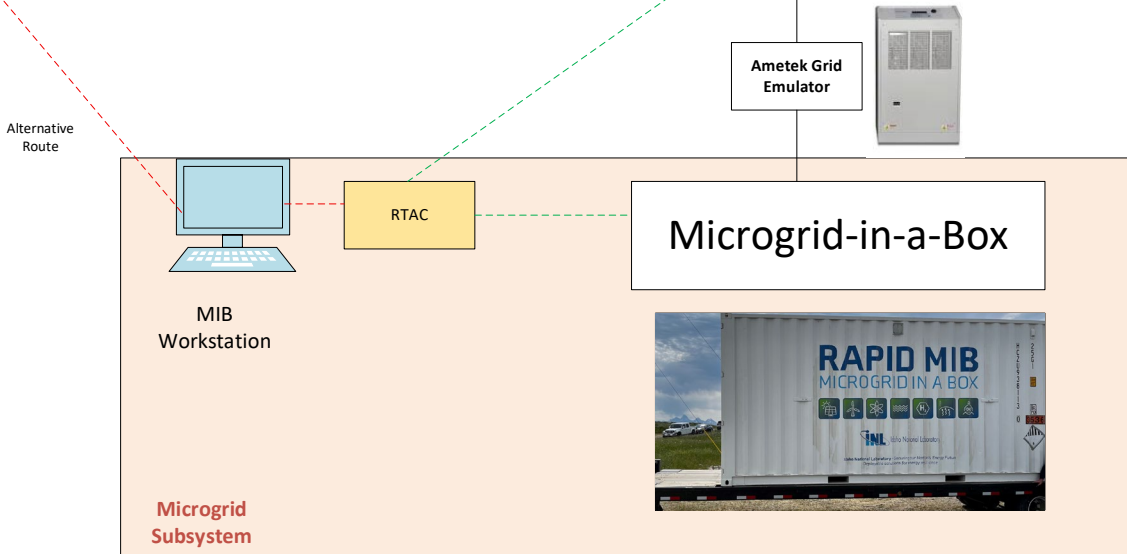
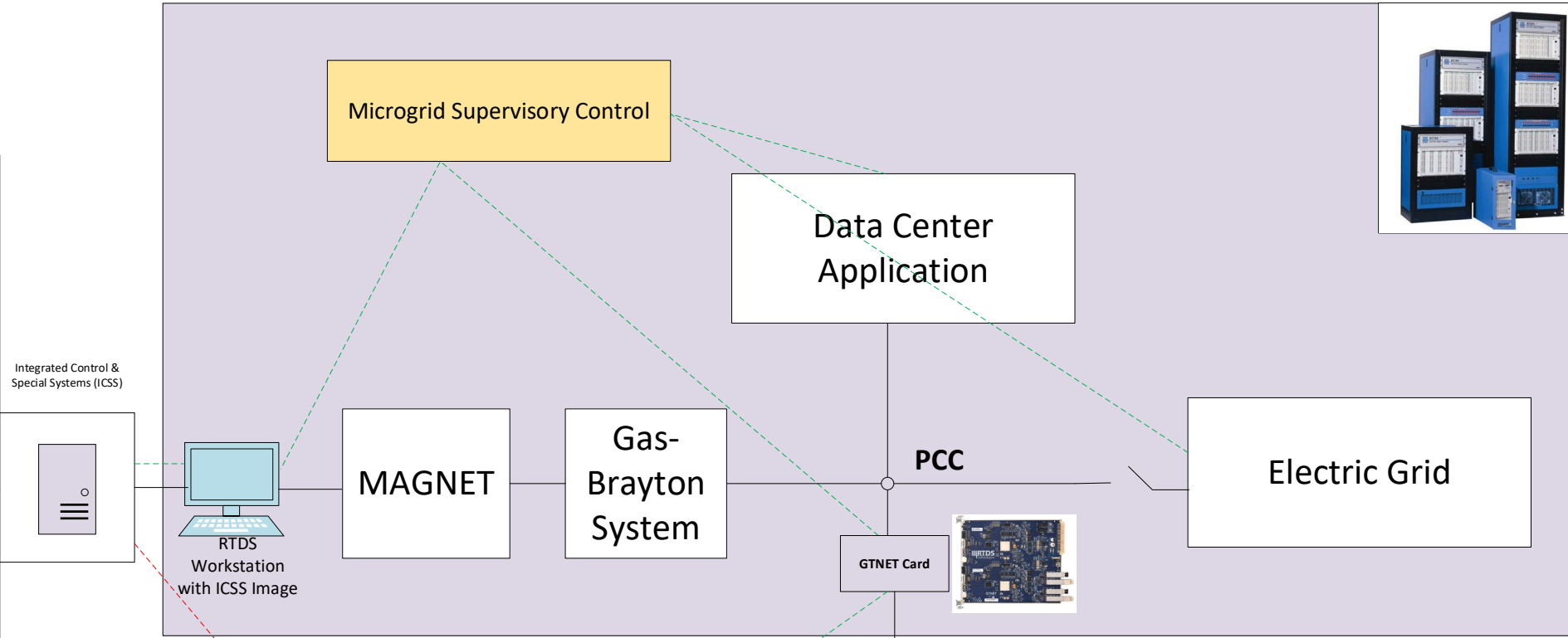
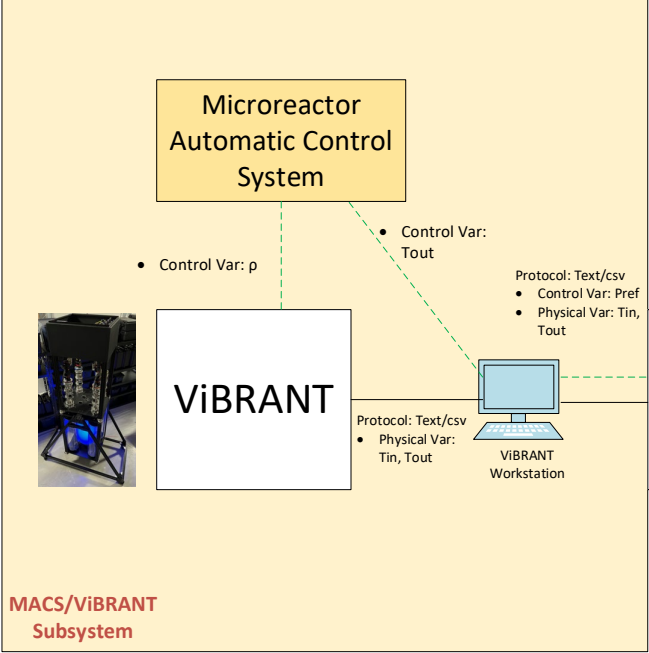

Nuclear Powered Microgrids

Vision: Strengthen grid reliability and security through swift implementation of nuclear energy for uses into microgrid to unleash American innovation

Why nuclear powered microgrids?

- **Optimize:** shorten fuel and water supply line for U.S military and dominance of space exploration
- **Stabilize:** remove barriers for data centers “bring your own power” and enhance grid reliability and resilience for critical infrastructure
- **Grow:** provide a key source of power for AI, industrial and mining dominance

Measures of Success

6 Months	Test platform for control and system development with Microgrid in a Box	August 2026
10 Months	Implement with nuclear reactor emulation representation - MAGNET	October 2026
18 Months	Build mobile development framework, platform, and standards for Nuclear Powered Microgrids (NPMs)	August 2027
24 months	First NPM with MARVEL microreactor demonstration	2028

Small Reactor in Microgrid Feasibility and Testing Framework

The Framework

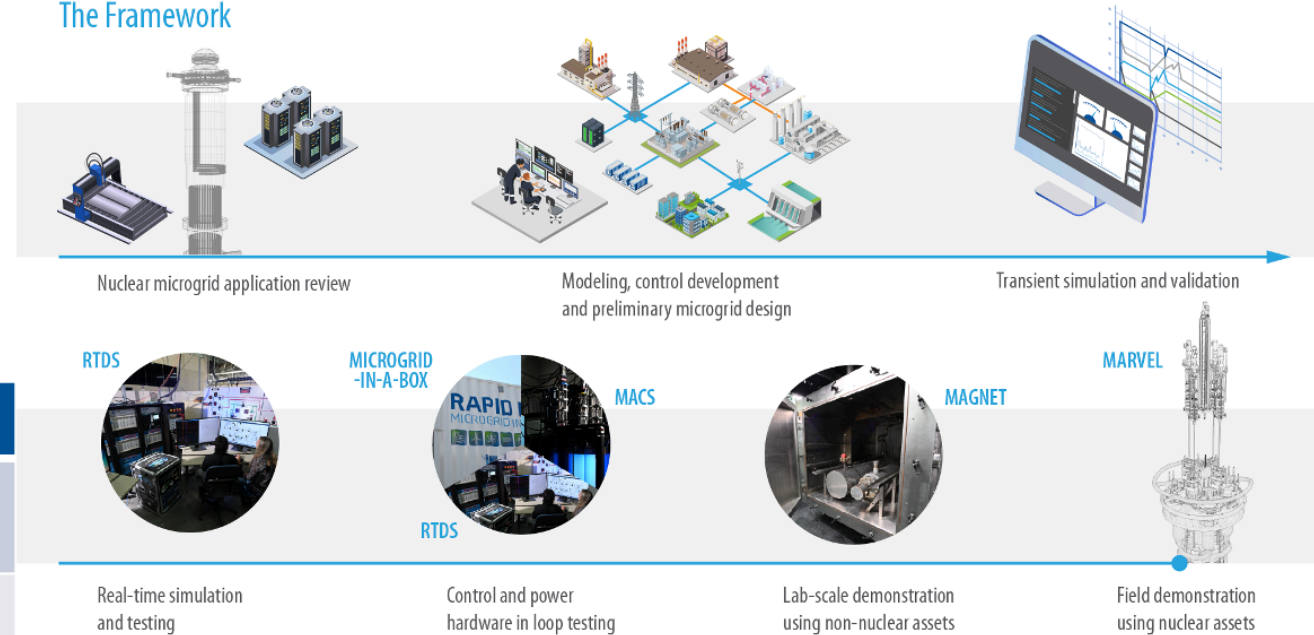

Exemplar use of NPM framework:

- Realize the world's first NPM with DOE-NE's MARVEL microreactor and Microgrid-in-a-Box
- Establish the tools and replicable design process for scalable to any microgrid application and any commercially viable advanced nuclear reactor technology



Ryan Davis
Ryan.Davis@inl.gov
Tim McJunkin
Timothy.mcjunkin@inl.gov
INL Nuclear Powered Microgrid Team
NPM@inl.gov

Battelle Energy Alliance manages INL for the U.S. Department of Energy's Office of Nuclear Energy. INL is the nation's center for nuclear energy research and development, and also performs research in each of DOE's strategic goal areas: energy, national security, science and the environment.