



Realizing Innovation in Advanced Reactors

GAIN-EPRI-NEI-US NIC MICRO-REACTOR WORKSHOP

Stewart Magruder, Senior Project Manager

Division of Advanced Reactors

June 19, 2019



Non-Light Water Reactor Landscape

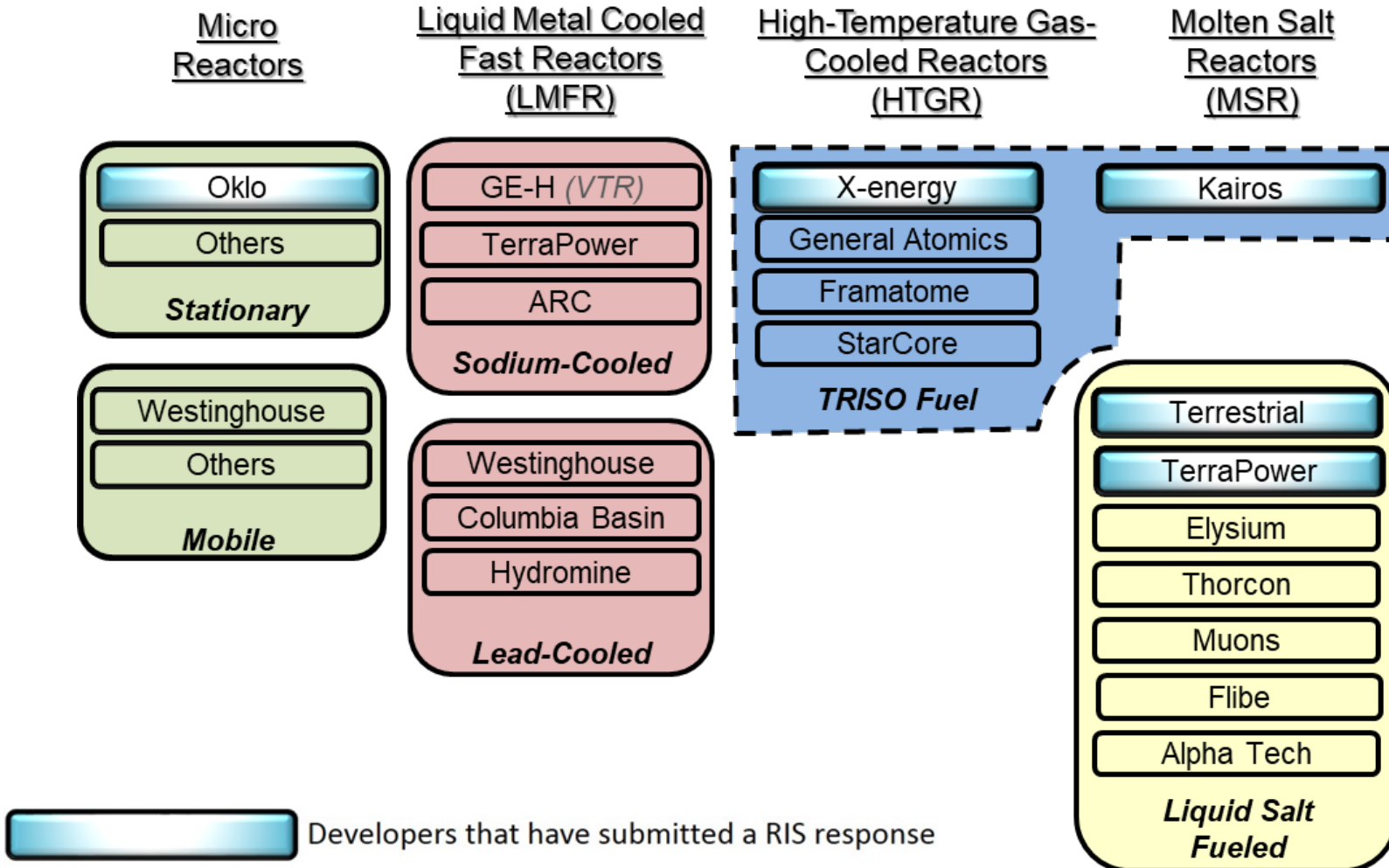

NRC's Advanced Reactor Program Vision and Strategy

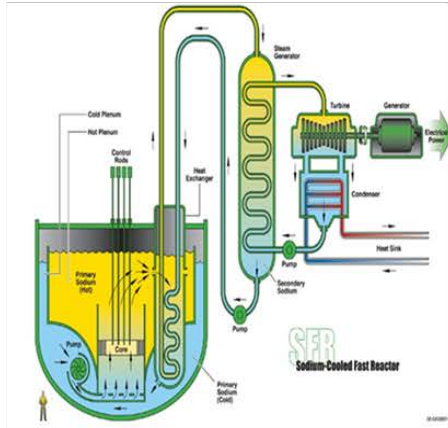

NRC Vision and Strategy:
 Safely Achieving Effective and Efficient
 Non-Light Water Reactor
 Mission Readiness

ML16356A670

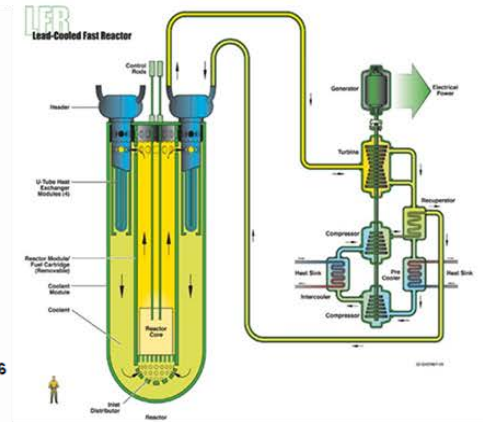
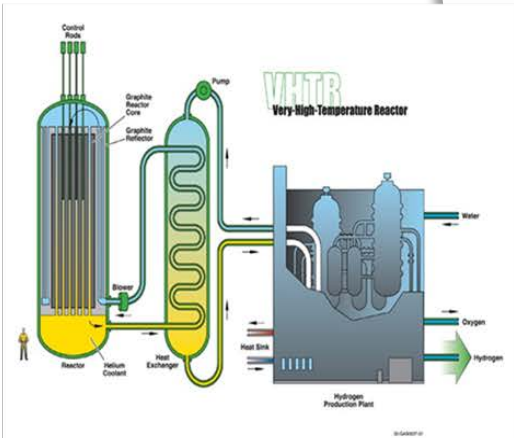
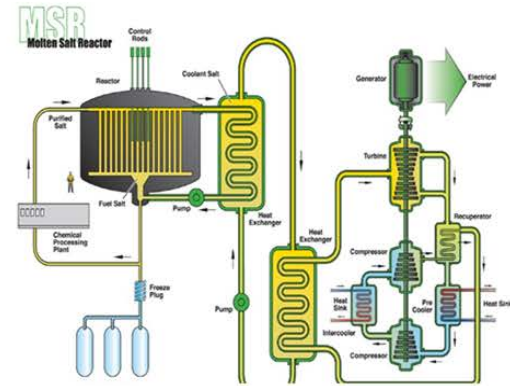
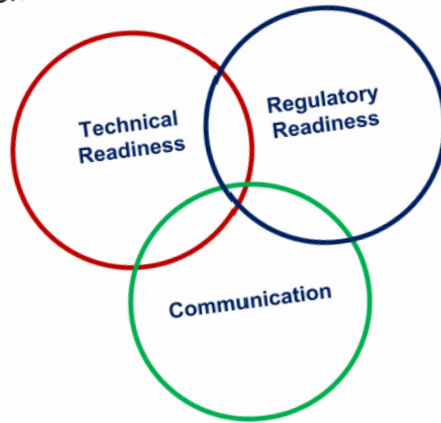

December 2016

Implementation Action Plans

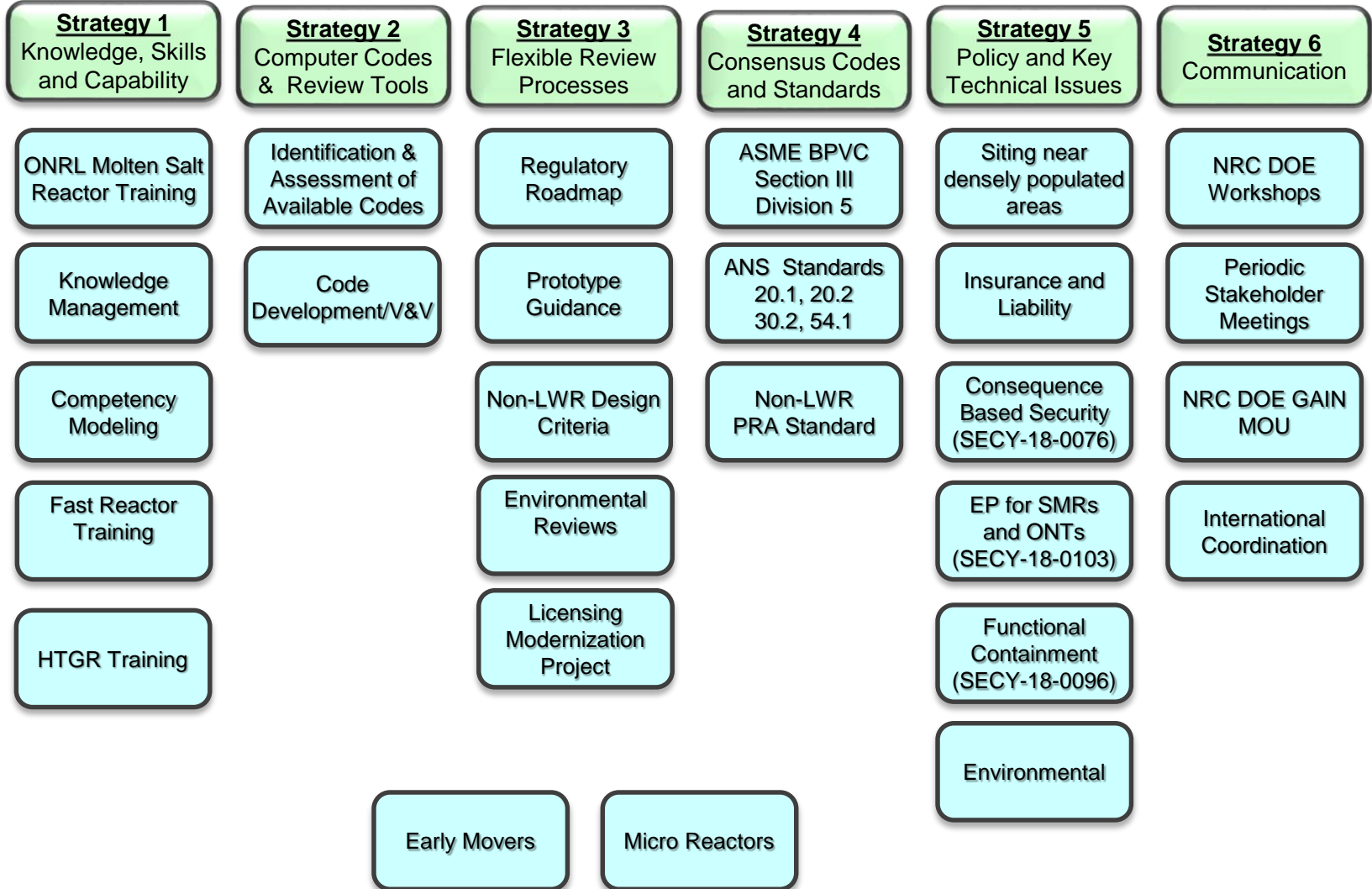

Potential Licensing Pathways

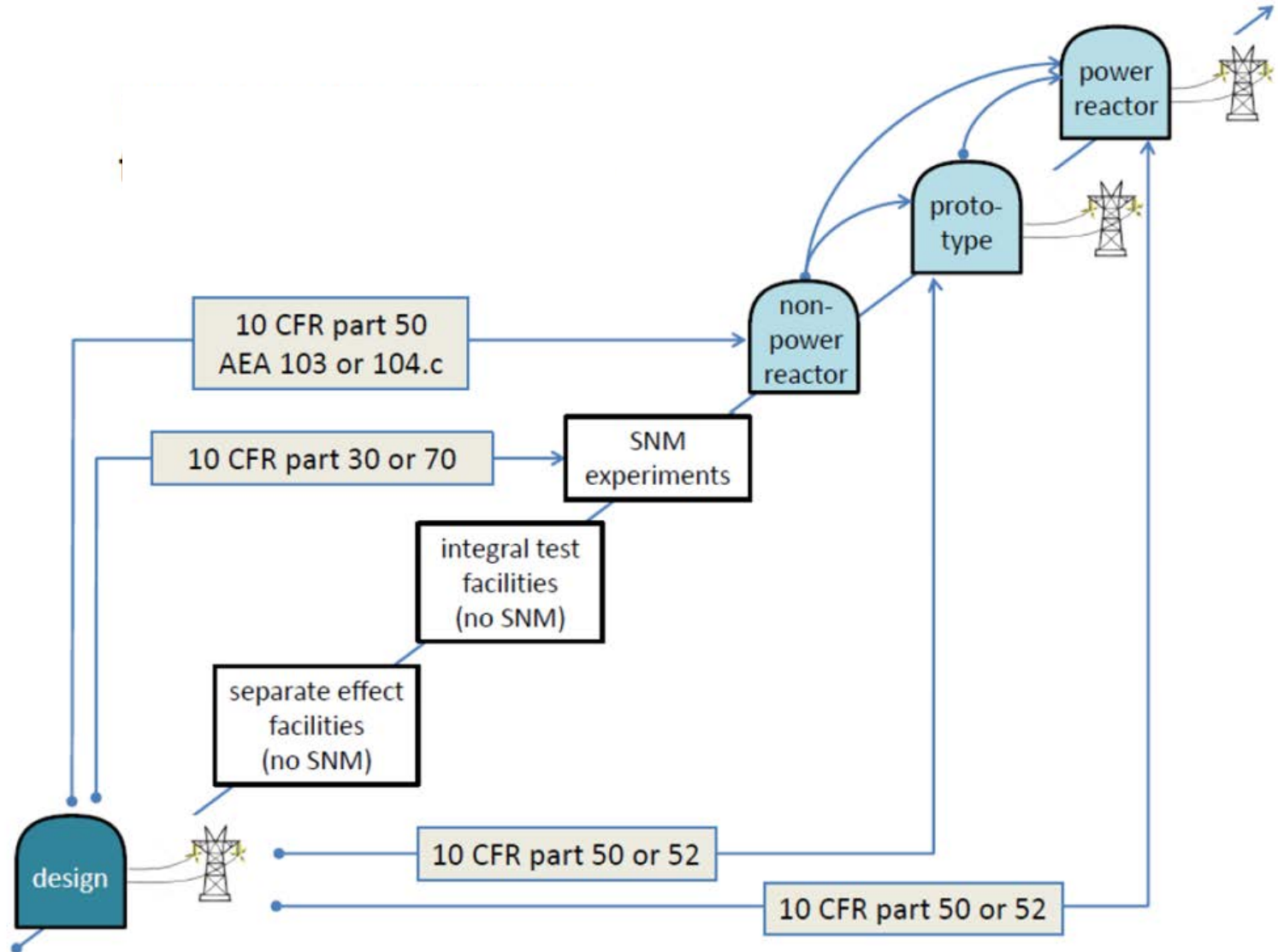

Flexible Regulatory Engagement

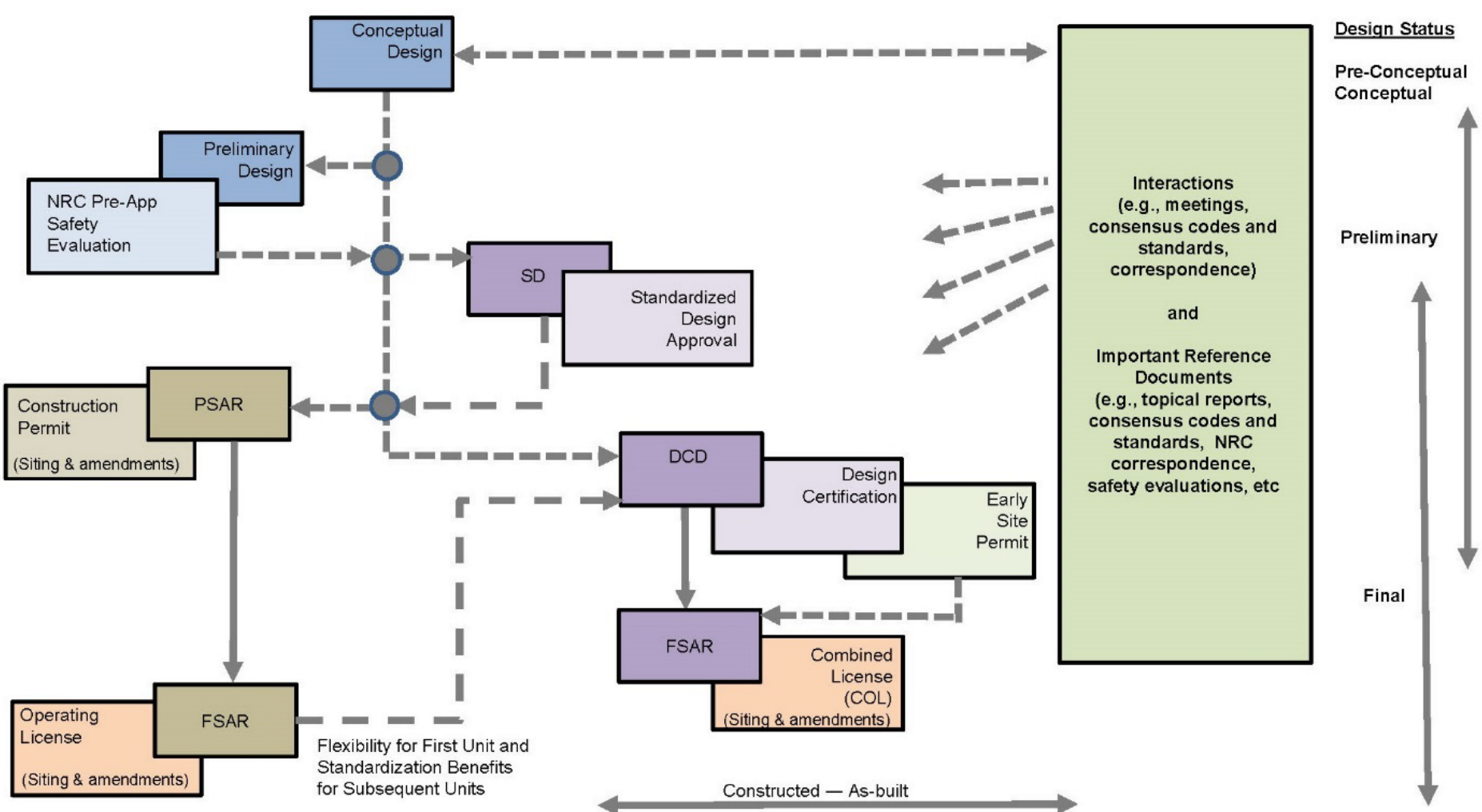

Fundamental Safety Functions and Mechanistic Source Term

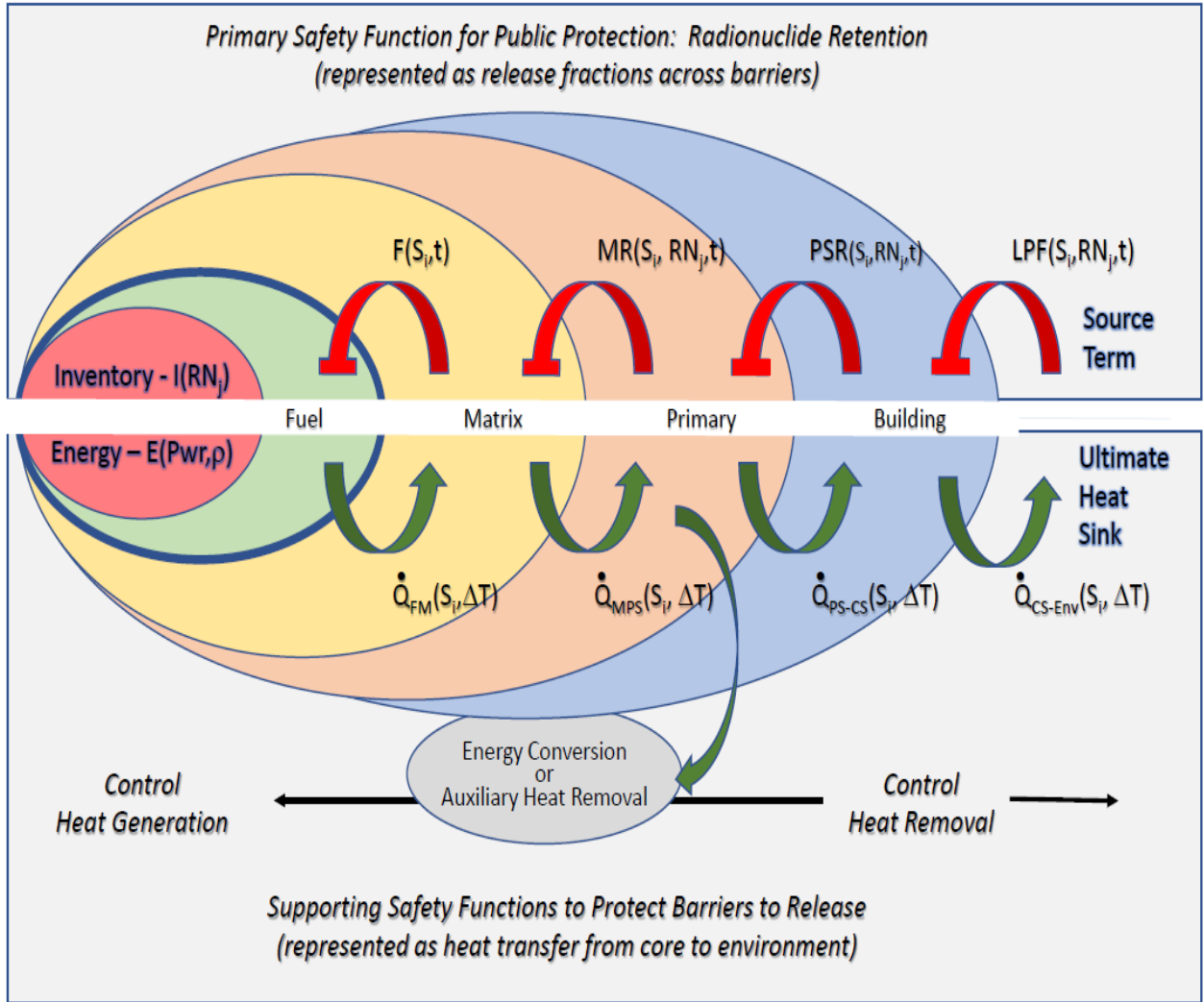

$I(RN_j)$	Inventory
RN_j	Radionuclide Groups (j)
E	Heat Energy
Pwr	Power Level
ρ	Reactivity
F	Fuel Release Fraction
MR	Matrix Release Fraction
PSR	Primary System Release Fraction
LPF	Building Leak Path Factor
S_i	Event Sequences (i)
t	Time
\dot{Q}	Heat Transfer
FM	Fuel to Matrix
MPS	Matrix to Primary System
$PS-CS$	Primary System to Cooling System
$CS-Env$	Cooling System to Environment
ΔT	Temperature difference

Licensing Modernization Project (LMP)

- Nuclear Energy Institute Technical Report (NEI 18-04)
“Modernization of Technical Requirements for Licensing of Advanced Non-Light Water Reactors”
 - Risk-Informed Performance-Based Guidance for Non-Light Water Reactor Licensing Basis Development
- NRC issued Draft Regulatory Guide (DG-1353) for public comment on May 3, 2019
 - Endorses NEI 18-04 with some clarifications
 - One acceptable method
- The industry has conducted several pilots of LMP and more are planned

LMP Goals

- Selection of Licensing Basis Events
- Structures, Systems, and Components Classification
- Defense in Depth Assessment

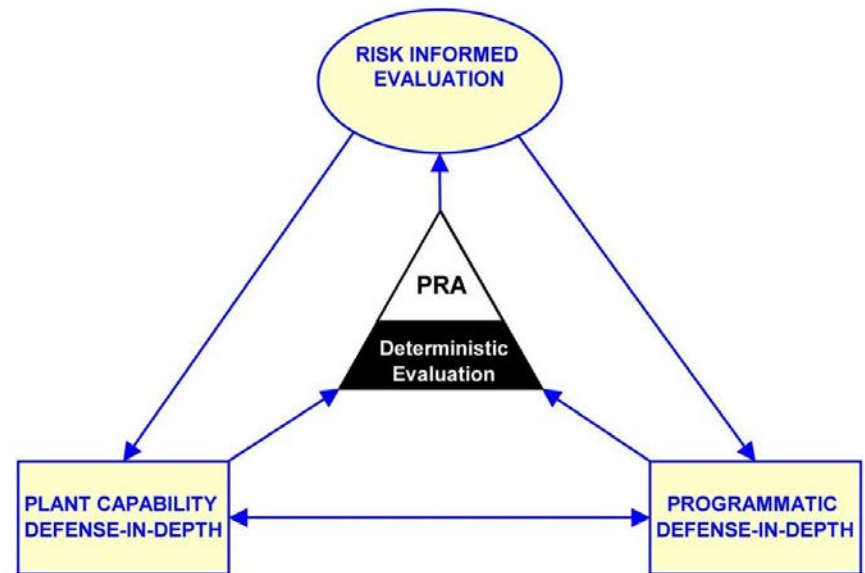
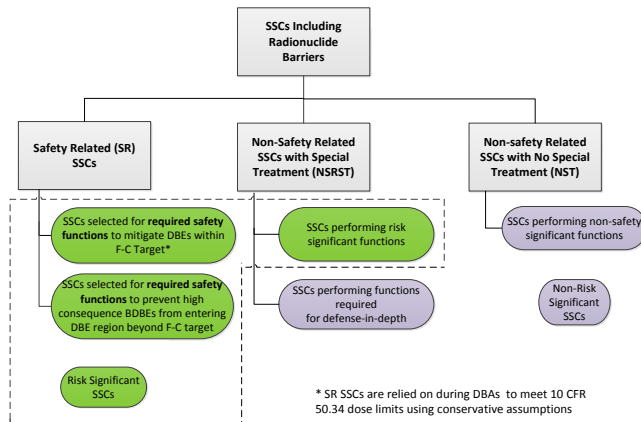
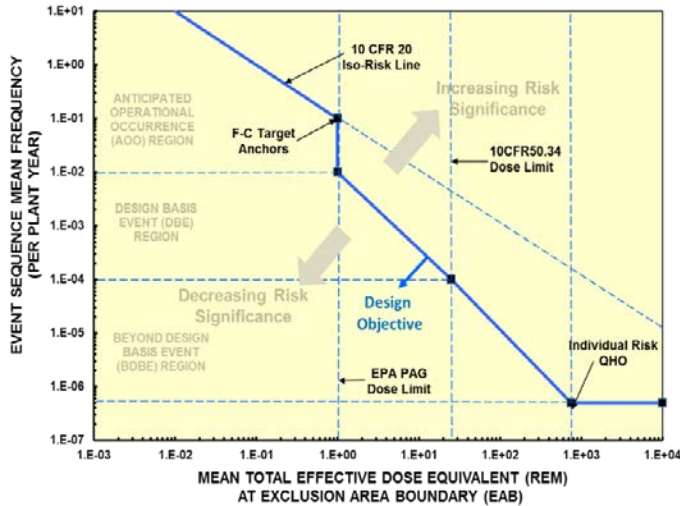

- Advanced Reactor Design Criteria
- Functional Containment Performance
- Emergency Planning Requirements
- Security Requirements
- Siting Guidance
- Industry Codes & Standards (e.g., ASME Section III, Division 5, Non-LWR PRA Standard)

Micro Reactors

- Department of Energy/Department of Defense interest
- Pushing the envelope further
 - Emergency Planning
 - Minimal Security
 - Minimal Staffing
 - Remote/Autonomous Operations
 - Reduced Environmental Impacts
 - Siting
 - Oversight
 - Transportation (Portable)
- Need to scale review to consequences

Notable External Drivers

- Nuclear Energy Innovation Capability Act (NEICA)
- Nuclear Energy Innovation and Modernization Act (NEIMA)
 - Staged licensing
 - Risk-informed licensing
 - Technology-inclusive regulatory framework
- Stationary Micro-reactors - Nuclear Defense Authorization Act
- Portable Micro-reactors – Interfacing with DoD and DOE

Making Progress

(Quotes from November 27, 2018 Memo on Third Way Website)

The ability and willingness of the NRC to become more adaptive is crucial to continued investment in the diverse array of advanced nuclear technologies under development in the U.S.

Takeaways

NRC has a reputation for being rigid and inhospitable to innovation. For companies that are reimagining the design of a nuclear reactor, that makes it pretty tough to attract investment. But based on Third Way analysis, NRC has made major progress over the past few years to modernize its structure and processes to better accommodate advanced reactor developers. While licensing a new nuclear reactor will always be challenging, these steps are a positive indicator that NRC is willing to adjust in order to keep up with fast-evolving technologies.

"I'm encouraged by the current Commission and its dedication to efficiency and innovation. Change can start at the top, but it also must permeate to all levels of staff, if it is to have lasting and practical impact. I'm confident it can be done, but it will indeed require transformation."

As Dr. David Hill, Chief Technology Officer of Terrestrial Energy USA, has remarked, "Terrestrial Energy USA has been delighted with the amount of preparatory work the US NRC has done to ready itself to license the IMSR [Integrated Molten Salt Reactor] in the USA."

Conclusion

Through its transformative and collaborative efforts, the NRC is becoming more transparent, communicative, and flexible in its approach to the regulatory process and interactions with advanced reactor developers. Advanced reactor industry stakeholders are engaged with the Commission, and have acknowledged its willingness to adapt and innovate in its procedures. Although further adjustments are necessary, the NRC has endeavored to ensure its efforts to accommodate advanced reactor technologies in the regulatory process are feasible, effective, and holistic.

Addressing Challenges

- Planning for the broad range of designs under development, including various numbers, types and timing of applications
- Communicating with stakeholders to engage developers with limited regulatory experience
- Expanding NRC staff organizational capacity
- Ensuring coherence of new licensing approaches
- Pursuing paradigm shift in regulatory reviews



Thank you for your attention!



References

- NRC Vision and Strategy (ML16356A670)
- Implementation Action Plans (IAPs) (ML17165A069 and ML17164A173)
- Regulatory Review Roadmap including prototype guidance (ML17312B567)
- RG 1.232, "Guidance for Developing Principal Design Criteria for Non-Light Water Reactors" (ML17325A611)
- SECY-18-0011, "Advanced Reactor Program Status" (ML17334B217)
- SECY-19-0009, "Advanced Reactor Program Status" (ML18346A075)
- SECY-18-0076, "Option and Recommendations for Physical Security for Advanced Reactors" (ML18052B032)
- SECY-18-0096, "Functional Containment Performance" (ML18114A546)
- SECY-18-0113, "Proposed Rule: Emergency Preparedness for Small Modular Reactors and other New Technologies," (ML18134A086)
- NEI-18-04, "Risk-Informed Performance-Based Guidance for Non-Light Water Reactor Licensing Basis Development," (ML18271A172)
- DG 1353, "Guidance for a Technology-Inclusive, Risk-Informed, and Performance-Based Approach to Inform the Content of Applications," (ML18264A093)
- <https://www.thirdway.org/memo/against-all-expectations-the-modernization-of-the-nuclear-regulatory-commission>