

DOE-NE Microreactor Program Winter Review Meeting

Demonstration Capabilities Overview – Summary

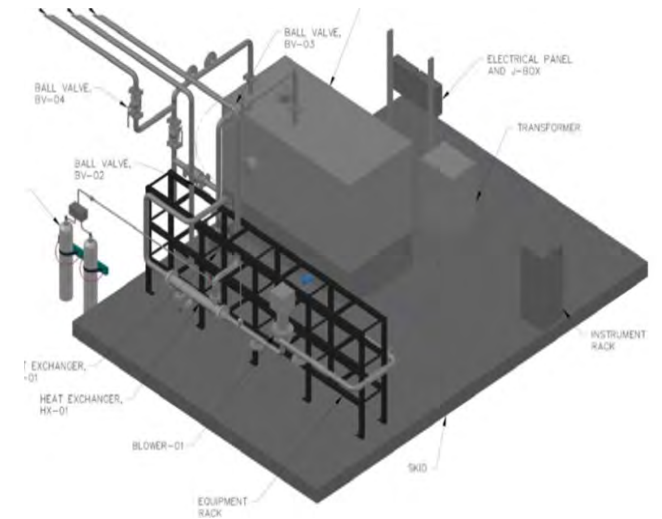

March 4, 2022

Piyush Sabharwall, Ph.D. | Technical Area Lead

Single Primary Heat Extraction and Removal Emulator (SPHERE)

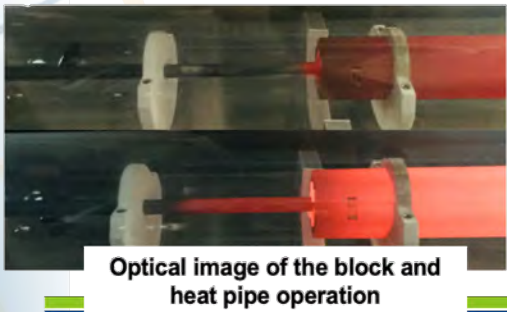

Objectives

- Provide **capabilities** to perform steady state and transient testing of heat pipes and heat transfer:
 - Wide range of heating values and operating temperatures
 - Observe **heat pipe startup and transient operation**
- **Measure** heat pipe axial temperature profiles during **startup, steady-state, and transient operation** using thermal imaging and surface measurements

Parameter	Value
Length	243 cm
Diameter	15 cm
Tube material	Quartz
Connections	Flanged for gas flow and instrumentation feed through
Maximum power	20 kW
Max Temperature	750 C
Heat Removal	Passive radiation or water-cooled gas gap calorimeter

Key Accomplishments

- SPHERE Initial Startup and Operation
- Complete Engineering Design of Gap Conductance Test Article
- Working Closely with DOE-NEAMS Prog to Jointly Support V&V Activities

In Progress

- Ongoing modifications for SPHERE facility
- Gap Conductance Testing for NRC
- Understanding the effect of orientation on heat pipe performance (Work for Others – Industrial Partner)

Challenges

- Testbed chamber is inadequate for accessibility and assembly
- TC routing too tight
- Secondary test article creates additional complexity
- Contact resistances are significant source of model error

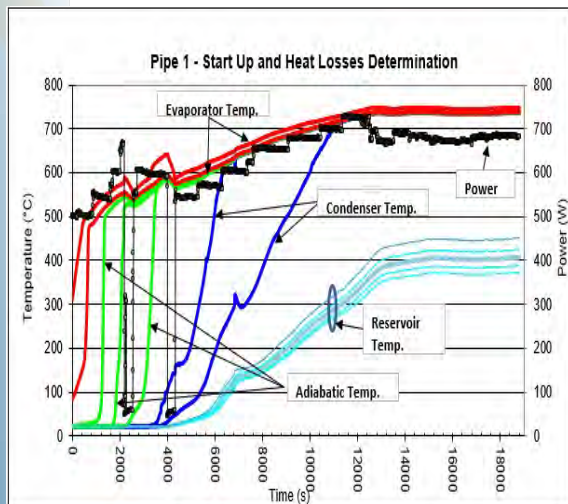

MAGNET Accomplishments

- Completed construction in November 2020
- Pressurized, started, and slightly heated system in January of 2021 for ASME B31.3 pressure testing
- A change in Engineer of Record for design and construction resulted in removal of insulation from all joints for a new B31.3 pressure test
- Discrepancy between installation drawings and as-built drawings resulted in removal of a section of piping to weld in a thermal expansion loop.
- Final pressure testing of reworked section of piping

Thermal expansion loop added to this section

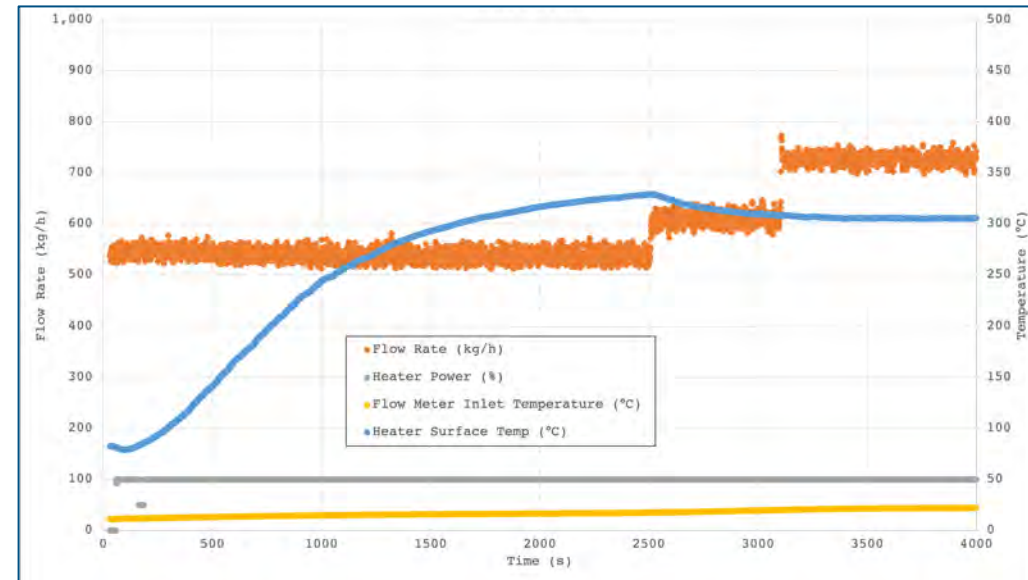

Startup Data

Ongoing Modification for MAGNET – He Component Test Facility

- Gas cooled reactors have been proposed to support several funded reactor demonstration projects. Most inert gaseous coolants such as Helium, Argon and Nitrogen are low molecular mass fluids and can be difficult to work with. Most design processes require that components be qualified to a **TRL of 6** prior to integration with a system. A test facility, or series of facilities is necessary in order to characterize and qualify critical reactor components in high-temperature flowing environments.
- The need to test full scale control drums, control rod assemblies, heat exchangers, pumps and re-circulators have been identified in discussion with reactor vendors. Currently no known facilities can accommodate these testing needs, especially for long duration reliability testing.
- Establishment of a Helium Component Test Facility (He-CTF) will support the development and deployment of advanced gas cooled reactors and technologies.

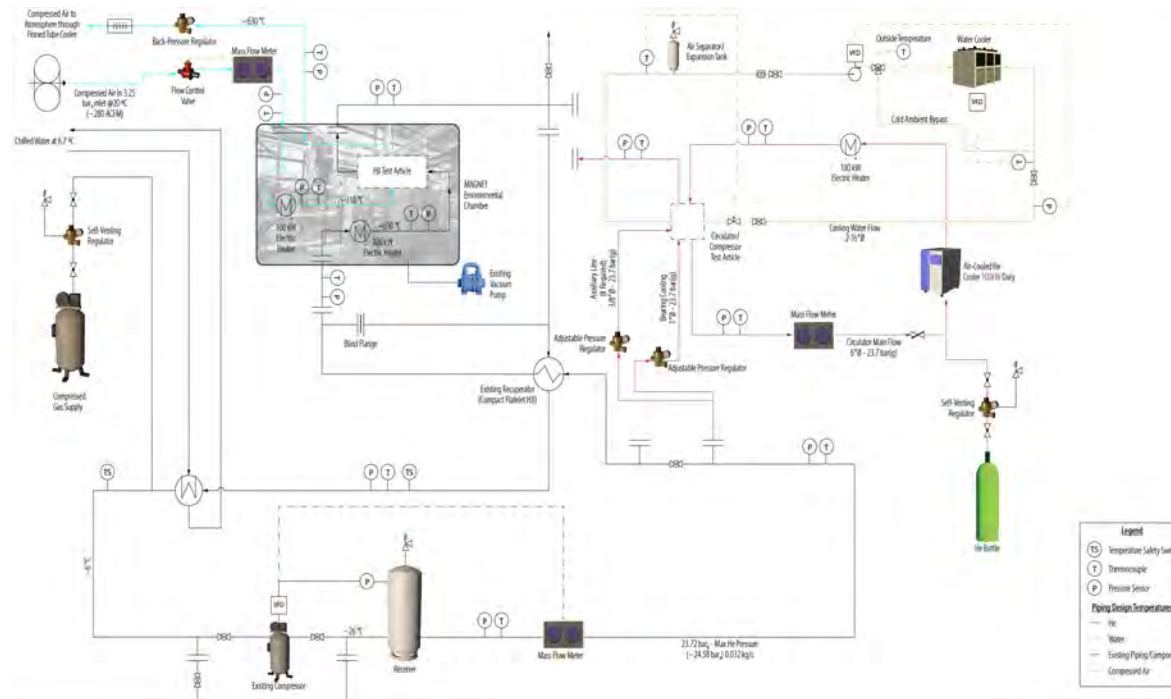

Potential Areas Where Industry Can Leverage SPHERE and MAGNET (Non-Nuclear Test Bed)

- Heat Pipe Thermal Performance
 - Startup and Shutdown
- Studying Cascading Failure and Its Effect
- High Temperature and Pressure Testing
 - Prototype microreactor design testing
 - Component Testing
- Instrumentation and Control
 - Advanced Manufactured Test Articles
 - Advanced Manufacturing Sensor Development
- Verification and Validation
 - Concepts with low TRL levels for better understanding
 - Addressing Technical Gaps and Data Requirement
- Interface and Coupling Different Systems
 - Heat Exchanger
 - PCU Integration
- Safety Basis
 - Design Margins



MAGNET Facility



- MAGNET Deployment in the INL Energy Systems Laboratory (ESL) building, Systems Integration Laboratory
- Co-located with the Thermal Energy Distribution System (TEDS) and the High-Temperature Steam Electrolysis (HTSE) System

Thermal Energy Distribution System (TEDS)

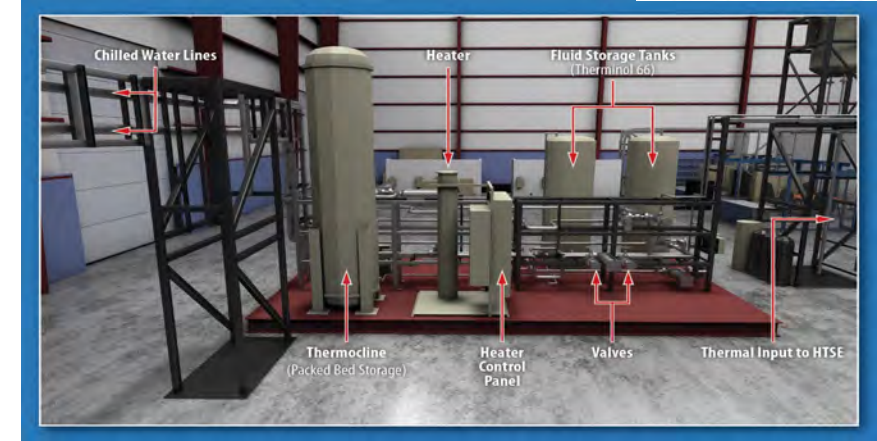
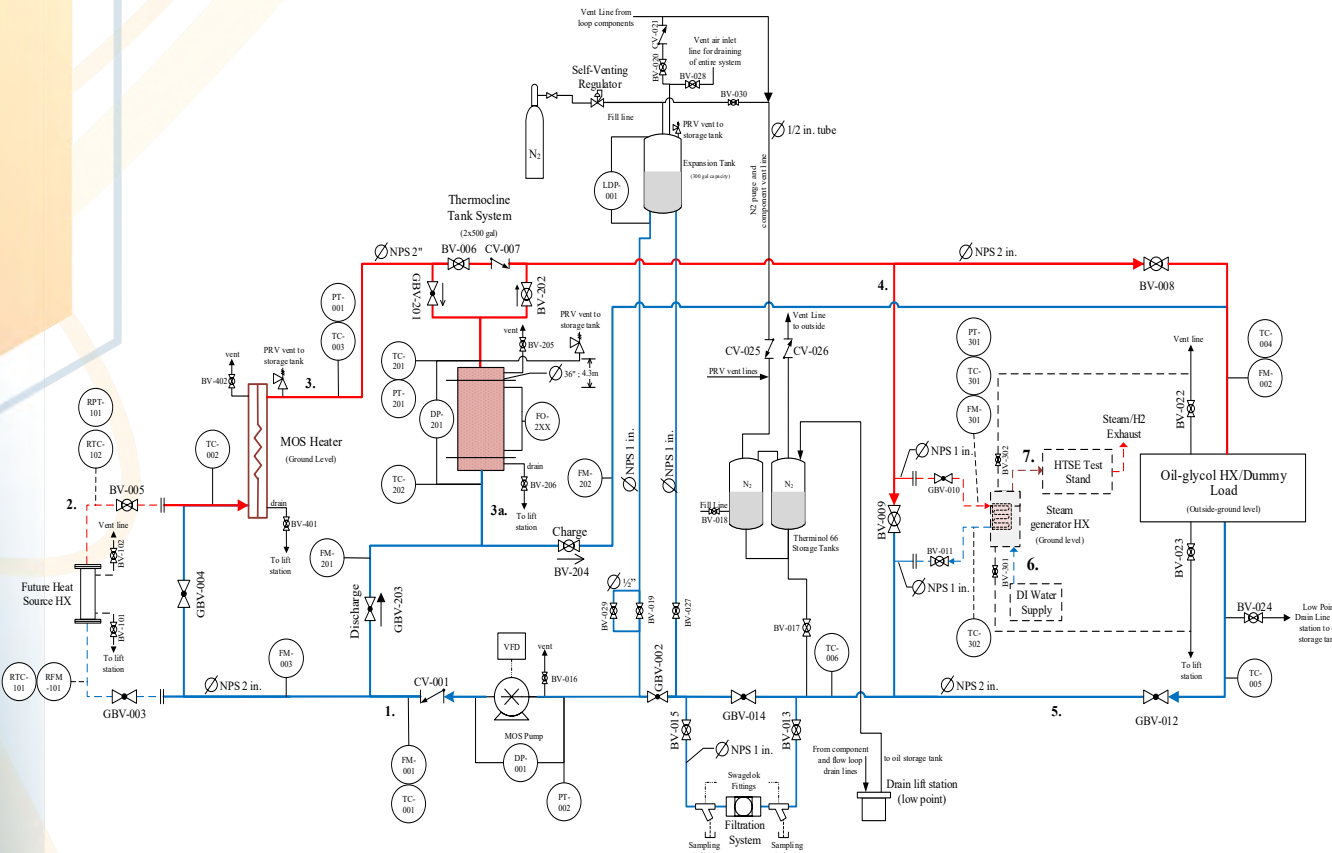

Condition	Value
Design Pressure	100 [psig]
Design Temperature	340[°C]
Maximum Oil Operating Temperature	325[°C]
Return Oil Operating Temperature	225[°C]
Maximum Operating Pressure	14 [psig]
Nominal flow rate	0.8-1.62 [kg/s] (14-33 [gpm])
Nominal Pipe Size (NPS)	2 [in.]

- Thermal network for transport of heat from thermal energy sources to thermal energy “customers”
- Independent thermal energy source; controllable heater (200kW)
- TEDS is designed with multiple flanges for future ancillary application connection

MAGNET Facility - Pics

INL Energy Systems Laboratory (ESL) building, Systems Integration Laboratory

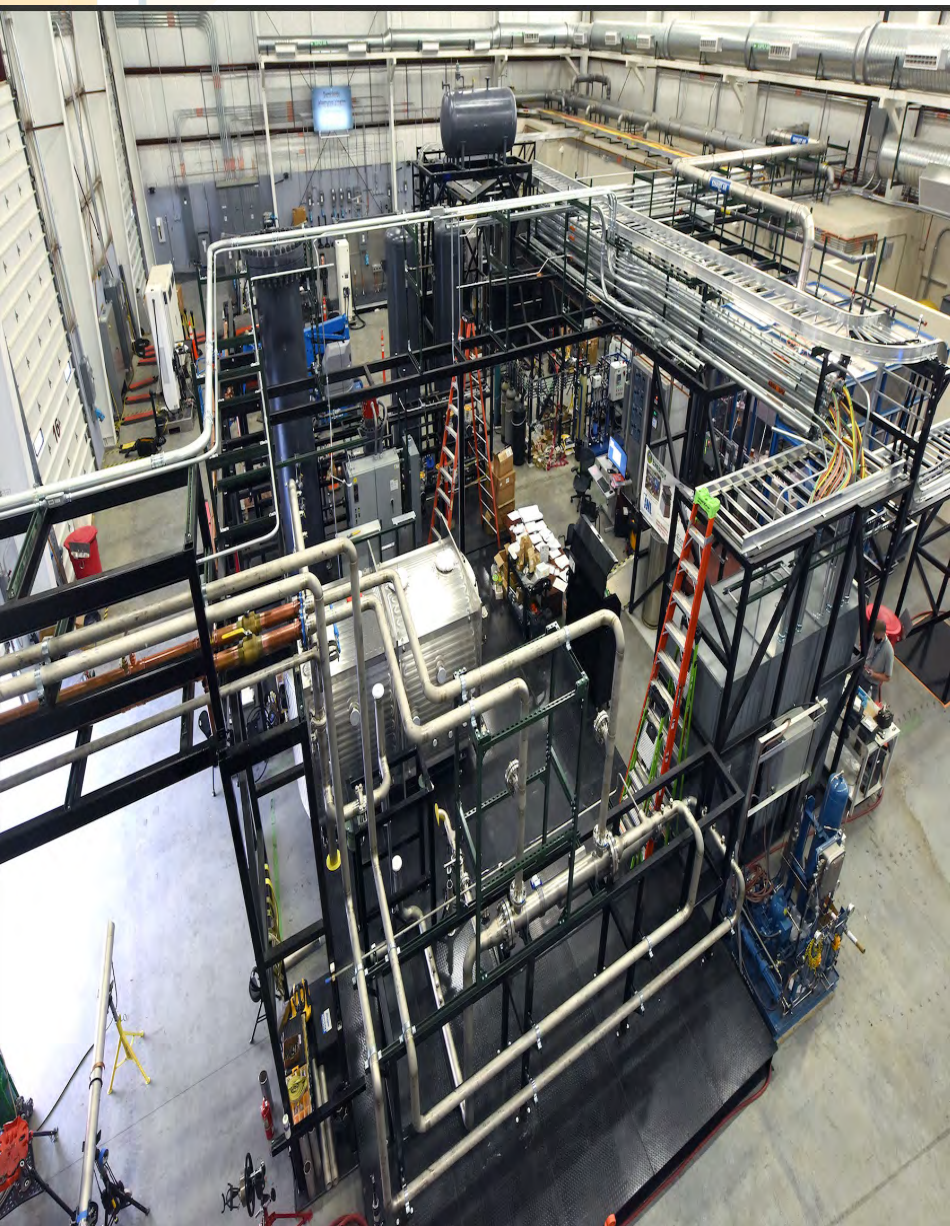

MAGNET & Co-Located Systems



Integrating systems for the nation's net-zero future

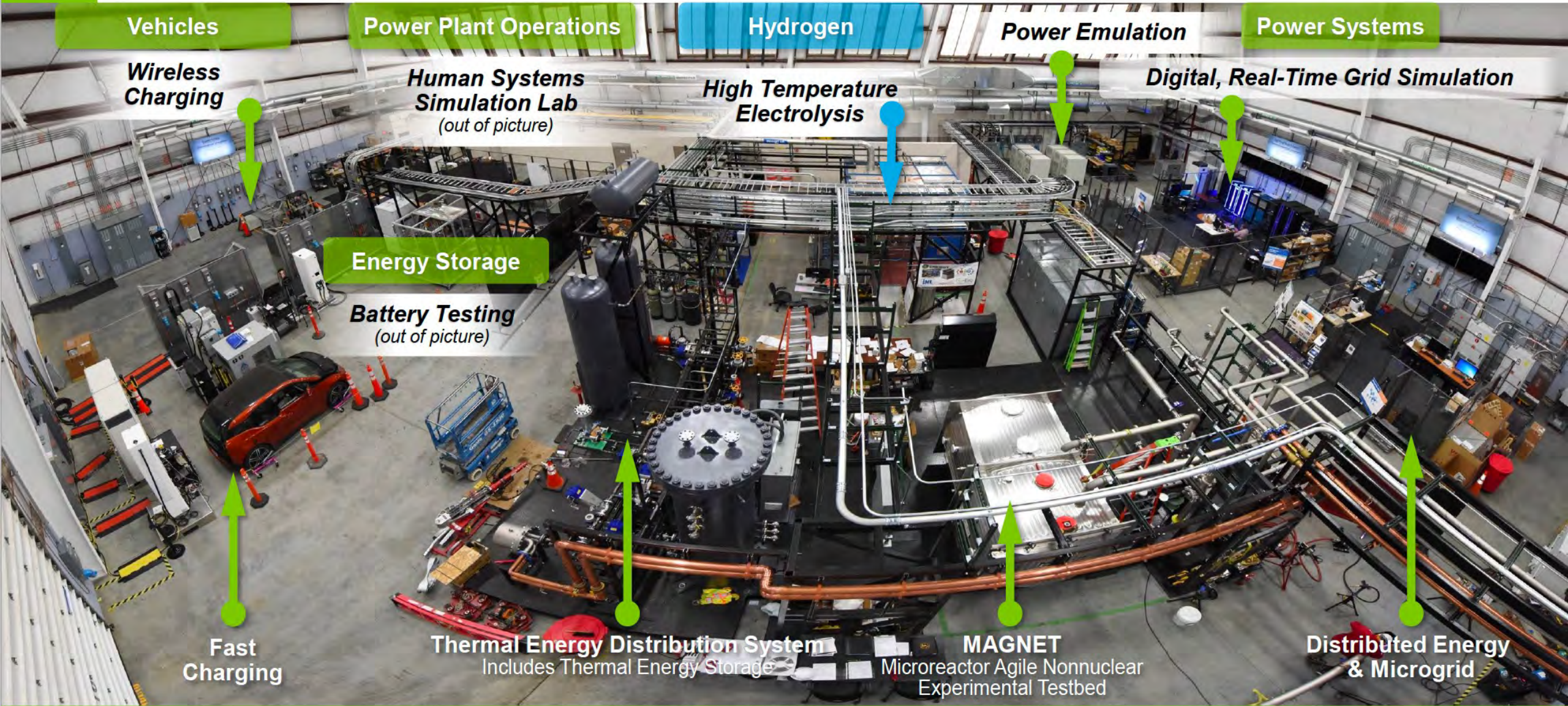

Vehicles

Power Plant Operations

Hydrogen

Power Emulation

Power Systems

Wireless Charging

Human Systems Simulation Lab
(out of picture)

High Temperature Electrolysis

Digital, Real-Time Grid Simulation

Energy Storage

Battery Testing
(out of picture)

Fast Charging

Thermal Energy Distribution System
Includes Thermal Energy Storage

MAGNET
Microreactor Agile Nonnuclear
Experimental Testbed

Distributed Energy & Microgrid

Main Conclusions

- Working closely with other DOE Programs to leverage and support joint efforts
- Regular interaction with industry through programs such as NRIC (ARDP funded projects)
- Interaction with Academia through DOE-NEUP program
- Bi-Monthly Meetings with PI's of NEUP's who are involved in experimental work
- This area did experience procurement delays due to pandemic, which did effect completion dates of milestones
- Successful demonstration are needed to gain utility, regulator, and public confidence.

Path Forward

SPHERE

- Completion of gap conductance testing
- Heat Pipe performance at different orientations, supporting industry needs
- V&V support for Sockeye

MAGNET

- Complete Single Heat pipe Test Campaign
- High Temperature Component Testing (HX, Circulator,.. Supporting industry needs)
- Installation of 75 kW (37 Heat Pipe) Test Article

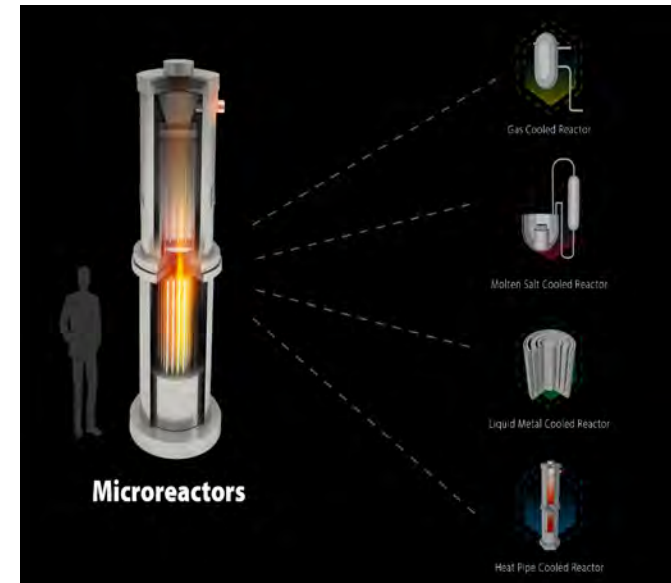

MRP Microreactor Program

Thank You..!

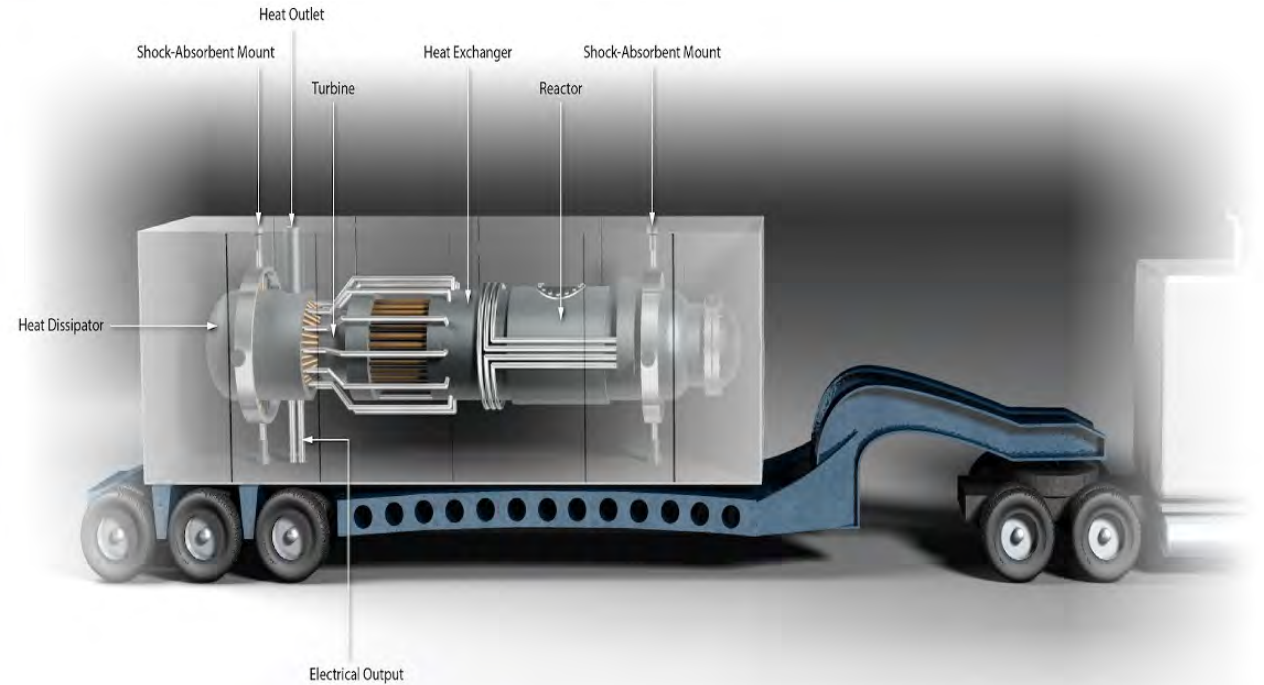
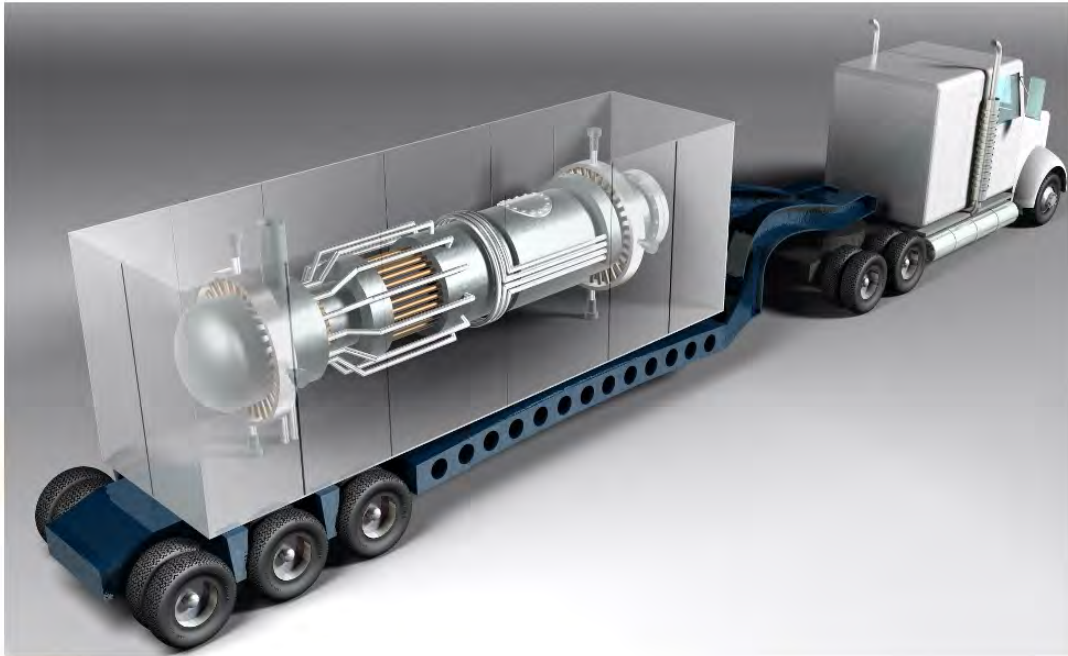

Piyush.Sabharwall@inl.gov

Credit
&
Acknowledgement



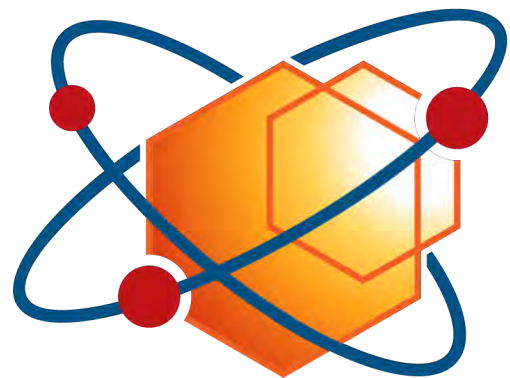

MRP Microreactor
Program